

ECE 111: Handout #13

Week #13: ECE 311 Circuits II & Phasors

1) Find the impedance Z_{ab}

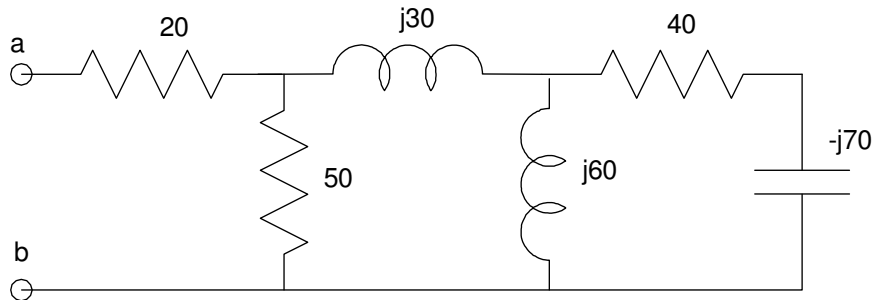

2) Convert each element to phasor form. Write the voltage node equations.

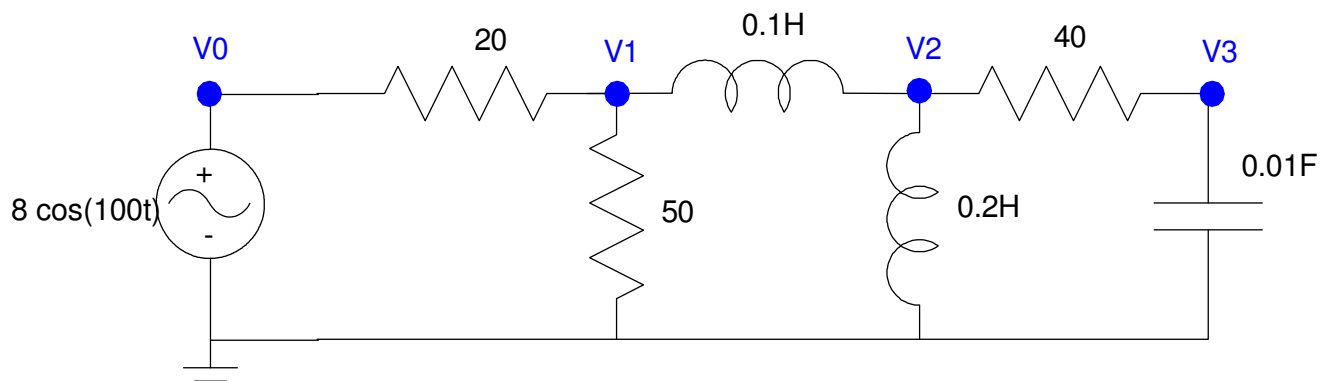

1) Find the impedance Z_{ab}

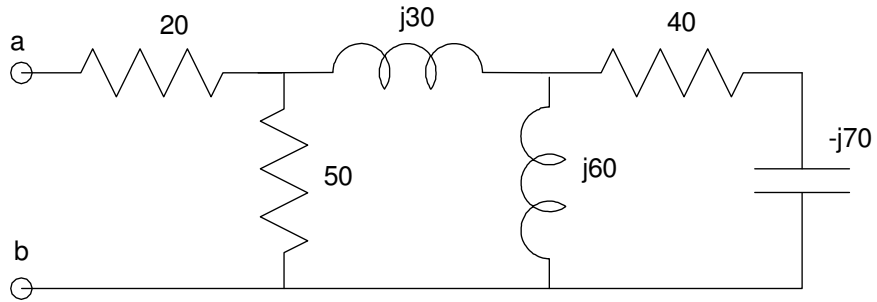

Going right to left:

$$(-j70) + (40) = 40 - j70$$

$$(40 - j70) \parallel (j60) = 84.7059 + j81.1765$$

$$(84.7059 + j81.1765) + (j30) = 84.7059 + j111.1765$$

$$(84.7059 + j111.1765) \parallel 50 = 38.9607 + j9.1111$$

$$(38.9607 + j9.1111) + (20) = 58.9607 + j9.1111$$

answer: $58.9607 + j9.1111$

2) Convert each element to phasor form. Write the voltage node equations.

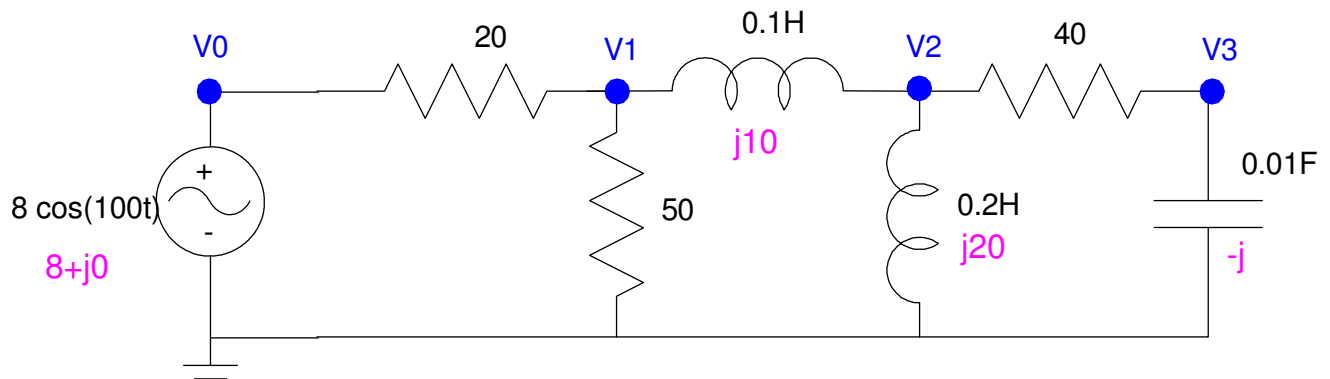

$$\omega = 100$$

$$8 \cos(100t) \rightarrow 8 + j0$$

$$0.1H \rightarrow j\omega L = j10$$

$$0.2H \rightarrow j\omega L = j20$$

$$0.01F \rightarrow \frac{1}{j\omega C} = -j1$$

The voltage node equations are then

$$V_0 = 8 + j0$$

$$\left(\frac{V_1 - V_0}{20} \right) + \left(\frac{V_1}{50} \right) + \left(\frac{V_1 - V_2}{j10} \right) = 0$$

$$\left(\frac{V_2 - V_1}{j10} \right) + \left(\frac{V_2}{j20} \right) + \left(\frac{V_2 - V_3}{40} \right) = 0$$

$$\left(\frac{V_3 - V_2}{40} \right) + \left(\frac{V_3}{-j} \right) = 0$$