

EE 206: Solution to Homework #9

Phasors, Passive Circuit Elements, Series and Parallel with Phasors, Voltage Nodes

Due Monday, April 1st

1) Find the frequency and phasor representation for the following voltages

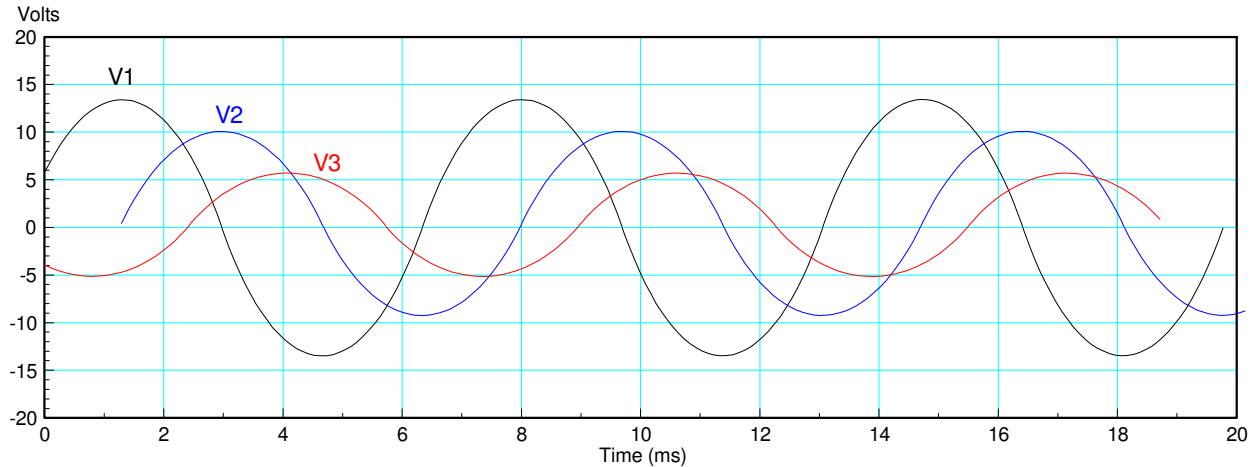

Period: $T = 6.2\text{ms}$

$$f = \frac{1}{6.2\text{ms}} = 161.29\text{Hz}$$

$$\omega = 2\pi f = 1013.4 \frac{\text{rad}}{\text{sec}}$$

	V1	V2	V3
Amplitude	14V	10V	6V
Delay (ms)	1.3ms	3.0ms	4.1ms
Delay (degrees)	-75.5 deg	-174 deg	-238 deg
phasor form	$14\angle -75.5^\circ$	$10\angle -174^\circ$	$6\angle -238^\circ$

Sample Calculation: V1:

Amplitude = 14V

Delay = 1.3ms

$$\theta = -\left(\frac{1.3\text{ms}}{6.2\text{ms}}\right) 360^\circ = -75.5^\circ$$

$$V_1 = 14\angle -75.5^\circ$$

2) Sketch $V(t)$. Assume 100Hz sine waves.

a) $V(t) = 15\angle -70^\circ$

$$T = \frac{1}{f} = 10ms$$

$$delay = \left(\frac{70^\circ}{360^\circ}\right) 10ms = 1.94ms$$

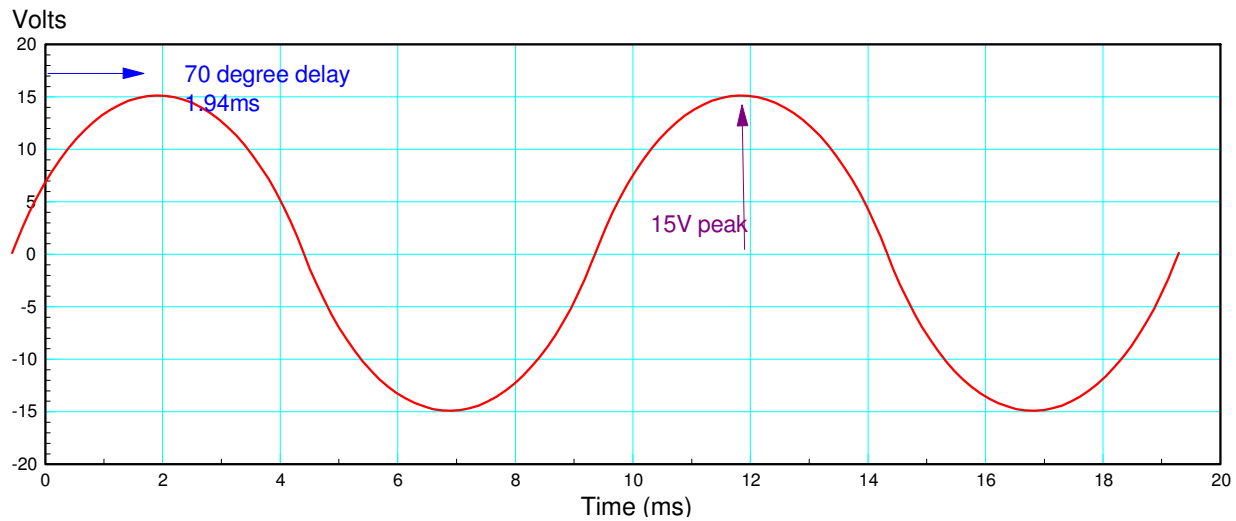

b) $V(t) = -5 - j10$

Convert to polar form

$$V(t) = 11.18\angle -116^\circ$$

$$delay = \left(\frac{116^\circ}{360^\circ}\right) 10ms = 3.22ms$$

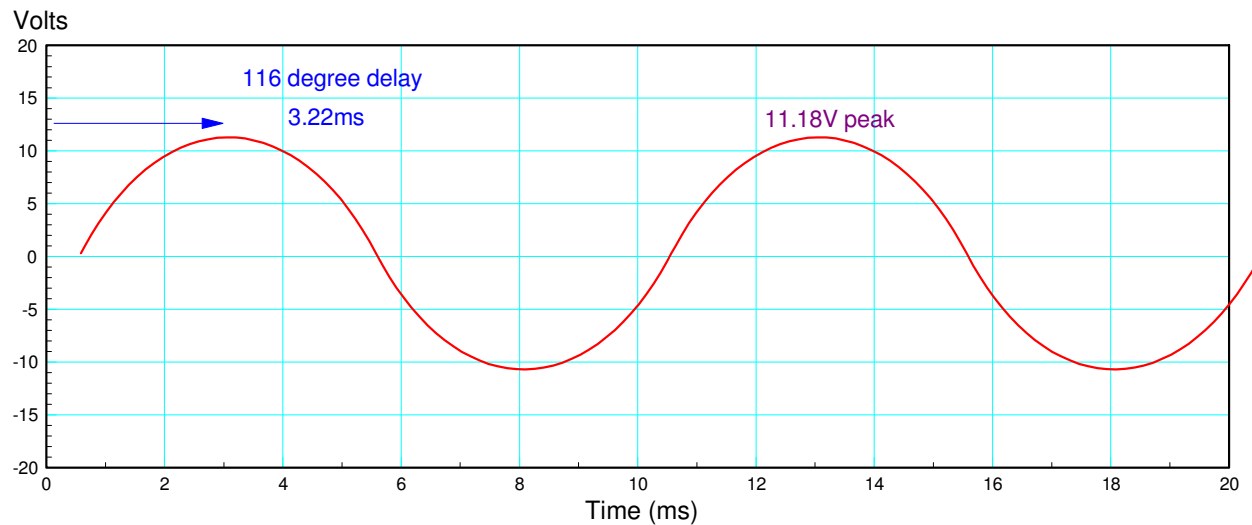

3) Determine the impedance of a resistor, inductor, and capacitor at 10, 1000, and 10k rad/sec

	R = 100 Ohms	L = 10mH	C = 10uF
10 rad/sec	100	j0.1	-j10,000
1000 rad/sec	100	j10	-j100
100k rad/sec	100	j1000	-j

Problem 4: Assume

$$V_{in} = 10 \cos(20t)$$

4a) Write the voltage node equations for the following circuit.

Convert to phasors

$$V_{in} = 10 + j0$$

$$\omega = 20 \frac{\text{rad}}{\text{sec}}$$

$$C \rightarrow \frac{1}{j\omega C}$$

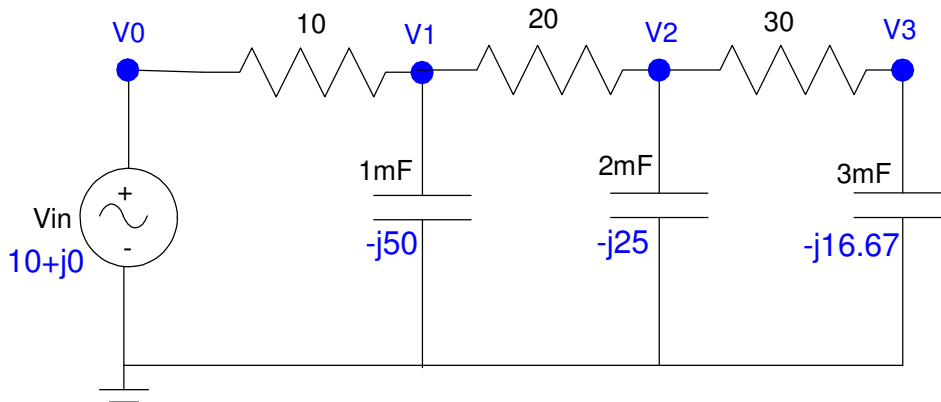

The node equations are then

$$V_0 = 10 + j0$$

$$\left(\frac{V_1 - V_0}{10} \right) + \left(\frac{V_1}{-j50} \right) + \left(\frac{V_1 - V_2}{20} \right) = 0$$

$$\left(\frac{V_2 - V_1}{20} \right) + \left(\frac{V_2}{-j25} \right) + \left(\frac{V_2 - V_3}{30} \right) = 0$$

$$\left(\frac{V_3 - V_2}{30} \right) + \left(\frac{V_3}{-j16.67} \right) = 0$$

4b) Solve for V1, V2, and V3

Group terms

$$V_0 = 10 + j0$$

$$-\left(\frac{1}{10}\right)V_0 + \left(\frac{1}{10} + \frac{1}{-j50} + \frac{1}{20}\right)V_1 - \left(\frac{1}{20}\right)V_2 = 0$$

$$-\left(\frac{1}{20}\right)V_1 + \left(\frac{1}{20} + \frac{1}{-j25} + \frac{1}{30}\right)V_2 - \left(\frac{1}{30}\right)V_3 = 0$$

$$-\left(\frac{1}{30}\right)V_2 + \left(\frac{1}{30} + \frac{1}{-j16.67}\right)V_3 = 0$$

Place in matrix form

$$\begin{bmatrix} 1 & 0 & 0 & 0 \\ \left(\frac{-1}{10}\right) & \left(\frac{1}{10} + \frac{1}{-j50} + \frac{1}{20}\right) & \left(\frac{-1}{20}\right) & 0 \\ 0 & \left(\frac{-1}{20}\right) & \left(\frac{1}{20} + \frac{1}{-j25} + \frac{1}{30}\right) & \left(\frac{-1}{30}\right) \\ 0 & 0 & \left(\frac{-1}{30}\right) & \left(\frac{1}{30} + \frac{1}{-j16.67}\right) \end{bmatrix} \begin{bmatrix} V_0 \\ V_1 \\ V_2 \\ V_3 \end{bmatrix} = \begin{bmatrix} 10 + j0 \\ 0 \\ 0 \\ 0 \end{bmatrix}$$

Solve using Matlab

```
A=[1, 0, 0, 0; -1/10, 1/10-1/(j*50)+1/20, -1/20, 0; 0, -1/20, 1/20-1/(j*25)+1/30, -1/30; 0, -1/30, 1/30-1/(j*16.67)]
```

```
1. 0 0 0
- 0.1 0.15 + 0.02i - 0.05 0
0 - 0.05 0.0833333 + 0.04i - 0.0333333
0 0 - 0.0333333 0.0333333 + 0.0599880i
```

```
B = [10; 0; 0; 0]
```

```
10.
0.
0.
0.
```

```
V = inv(A) * B
```

```
10.
7.2424841 - 2.0173573i
2.5343951 - 3.1550784i
- 0.7416442 - 1.8203858i
```

```
abs(V)
```

```
10.
7.5181983
4.0469345
1.9656655
```

```
angle(V) * 180 / %pi
```

```
0.
- 15.56491
- 51.225963
- 112.16649
```

4c) Simulate this circuit in PartSim and check your answers

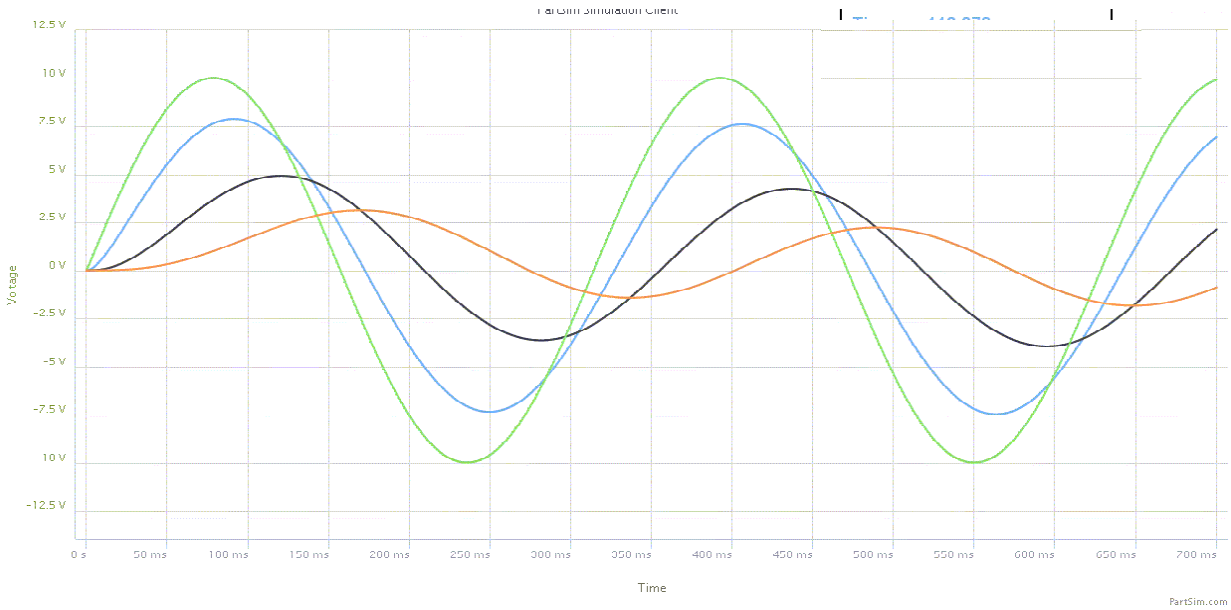

	Calculated	PartSim	comment
V0	$10\angle 0^{\circ}$	$10\angle 0^{\circ}$	zero degrees by definition
V1	$7.52\angle -15.56^{\circ}$	$7.33\angle -13.8^{\circ}$	
V2	$4.04\angle -51.22^{\circ}$	$4.67\angle -48.46^{\circ}$	
V3	$1.96\angle -112.17^{\circ}$	$2.00\angle -100.38^{\circ}$	

Sample Calculation: V1 (on my computer monitor)

- Measures 33mm tall
- With a delay of 4mm relative to V0
- The period of V1 is 104mm
- 10.0V measures 45mm high

This works out to

$$V_1 = (33mm) \left(\frac{10V}{45mm} \right) = 7.33V$$

$$\theta = -(4mm) \left(\frac{360^{\circ}}{104mm} \right) = -13.8^{\circ}$$

Problem 5) Assume

$$V_{in} = 5 \sin(30t)$$

5a) Write the voltage node equations for the following circuit

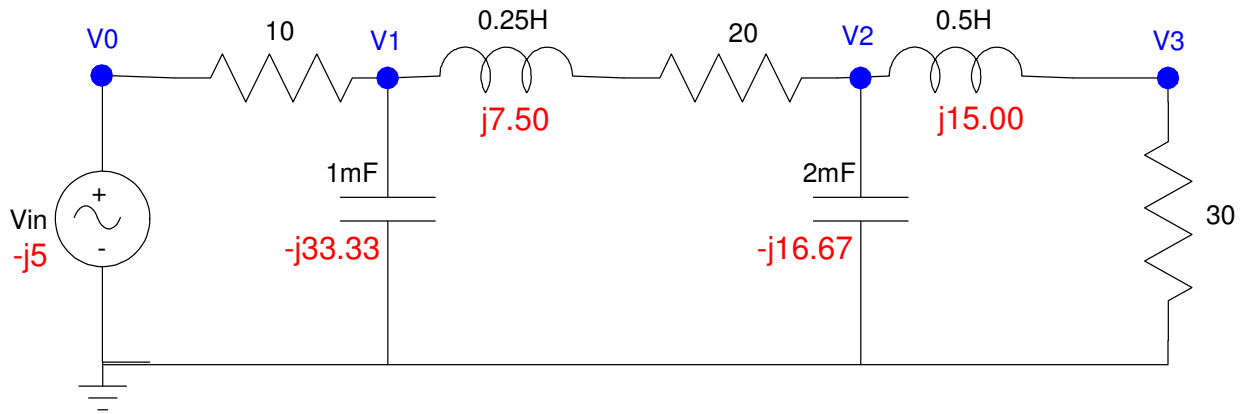

The phasor representation of each element is

$$V_{in} = 0 - j5$$

$$1mF \rightarrow \frac{1}{j\omega C} = \frac{1}{j \cdot 30 \cdot 0.001} = -j33.33\Omega$$

$$2mF \rightarrow -j16.67\Omega$$

$$0.25H \rightarrow j\omega L = j7.50\Omega$$

$$0.5H \rightarrow j15.00\Omega$$

Now write the voltage node equations

$$V_0 = -j5$$

$$\left(\frac{V_1 - V_0}{10} \right) + \left(\frac{V_1}{-j33.33} \right) + \left(\frac{V_1 - V_2}{20 + j7.50} \right) = 0$$

$$\left(\frac{V_2 - V_1}{20 + j7.50} \right) + \left(\frac{V_2}{-j16.67} \right) + \left(\frac{V_2 - V_3}{j15.00} \right) = 0$$

$$\left(\frac{V_3 - V_2}{j15.00} \right) + \left(\frac{V_3}{30} \right) = 0$$

5b) Solve for V1, V2, and V3

Group terms

$$V_0 = -j5$$

$$\left(\frac{-1}{10}\right)V_0 + \left(\frac{1}{10} + \frac{1}{-j33.33} + \frac{1}{20+j7.50}\right)V_1 + \left(\frac{-1}{20+j7.50}\right)V_2 = 0$$

$$\left(\frac{-1}{20+j7.50}\right)V_1 + \left(\frac{1}{20+j7.50} + \frac{1}{-j16.67} + \frac{1}{j15.00}\right)V_2 + \left(\frac{-1}{j15.00}\right)V_3 = 0$$

$$\left(\frac{-1}{j15.00}\right)V_2 + \left(\frac{1}{j15.00} + \frac{1}{30}\right)V_3 = 0$$

Place in matrix form

$$\begin{bmatrix} 1 & 0 & 0 & 0 \\ \left(\frac{-1}{10}\right) & \left(\frac{1}{10} + \frac{1}{-j33.33} + \frac{1}{20+j7.50}\right) & \left(\frac{-1}{20+j7.50}\right) & 0 \\ 0 & \left(\frac{-1}{20+j7.50}\right) & \left(\frac{1}{20+j7.50} + \frac{1}{-j16.67} + \frac{1}{j15.00}\right) & \left(\frac{-1}{j15.00}\right) \\ 0 & 0 & \left(\frac{-1}{j15.00}\right) & \left(\frac{1}{j15.00} + \frac{1}{30}\right) \end{bmatrix} \begin{bmatrix} V_0 \\ V_1 \\ V_2 \\ V_3 \end{bmatrix} = \begin{bmatrix} -j5 \\ 0 \\ 0 \\ 0 \end{bmatrix}$$

Solve in Matlab

```
a1 = [1,0,0,0];
a2 = [-1/10,1/10-1/(j*33.33)+1/(20+j*7.50),-1/(20+j*7.50),0];
a3 = [0,-1/(20+j*7.50),1/(20+j*7.50)-1/(j*16.67)+1/(j*15),-1/(j*15)];
a4 = [0,0,-1/(j*15),1/(j*15)+1/30];
```

```
A = [a1;a2;a3;a4]
```

```
1. 0 0 0
- 0.1 0.1438356 + 0.0135646i - 0.0438356 + 0.0164384i 0
0 - 0.0438356 + 0.0164384i 0.0438356 - 0.0231170i 0.0666667i
0 0 0.0666667i 0.0333333 - 0.0666667i
```

```
B = [-j*5;0;0;0]
```

```
-5.i
0
0
0
```

```
V = inv(A)*B
```

```
- 5.i
- 1.0442416 - 3.4914307i
- 1.9341058 - 1.0984305i
- 1.9866568 - 0.1051021i
```

abs (V)

5.
3.644246
2.224256
1.9894351

angle (V) *180/%pi

- 90.
- 106.65124
- 150.4066
- 176.97165

5c) Simulate this circuit in PartSim and check your answers

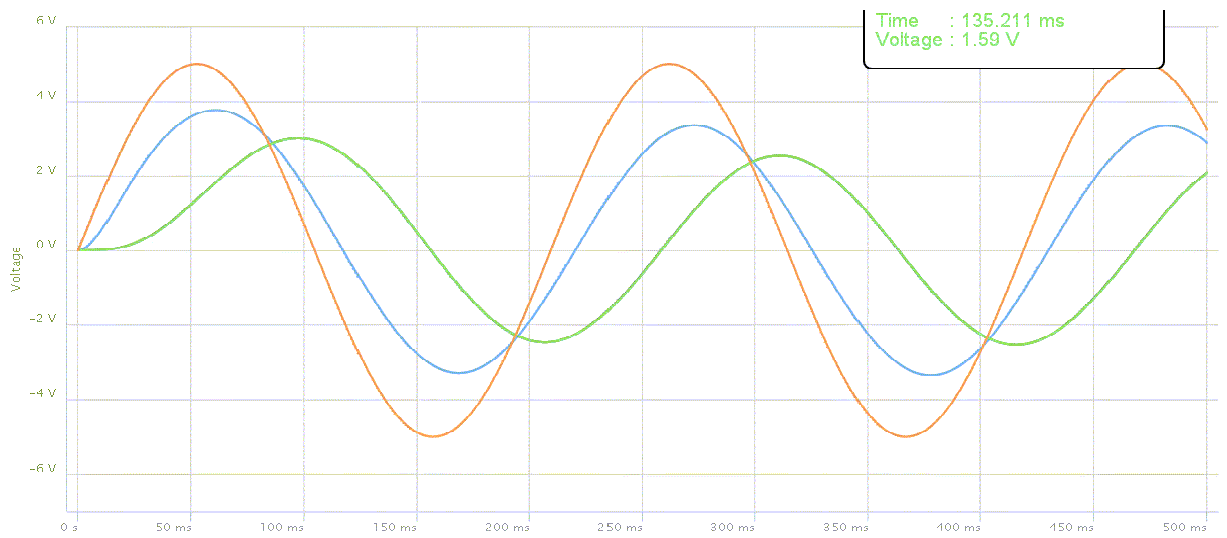

	Calculated	PartSim	comment
V0	$5\angle -90^0$	$5\angle -90^0$	phase by definition
V1	$3.64\angle -106^0$	$3.42\angle -108^0$	18 degrees delay relative to V0
V2	$2.22\angle -150^0$	$2.57\angle -173^0$	83 degree delay relative to V0
V3	$1.98\angle -176^0$	not shown	