

EE 206 Test #1b - Name _____

March 8, 2019

1a) Determine the resistance R_{ab}

$R_{ab} =$

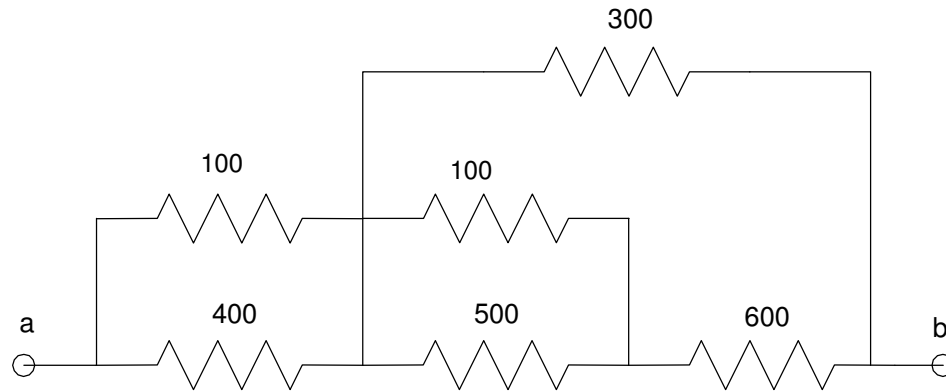

2) Write N equations to allow you to solve for the N unknown voltages

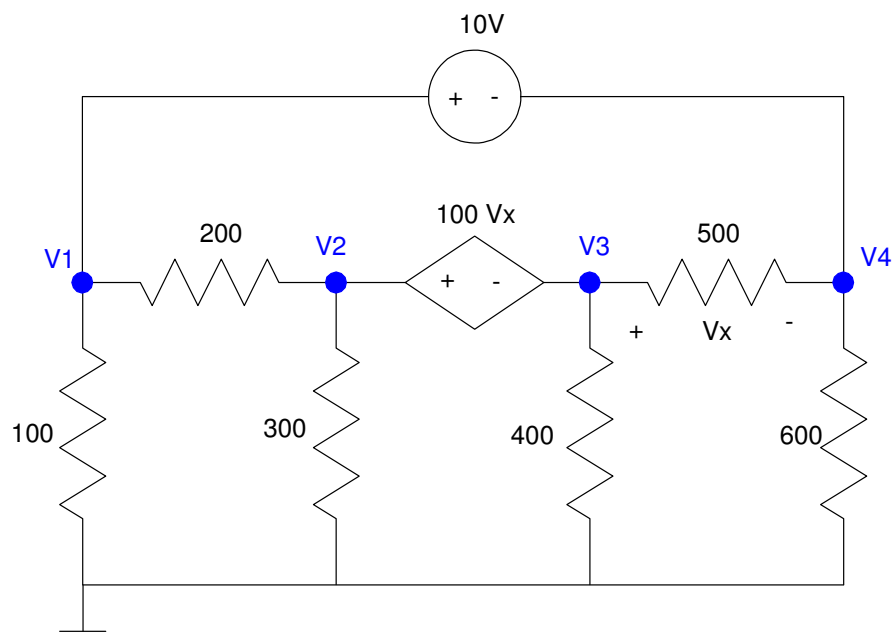

3) Write N equations to allow you to solve for the N unknown currents

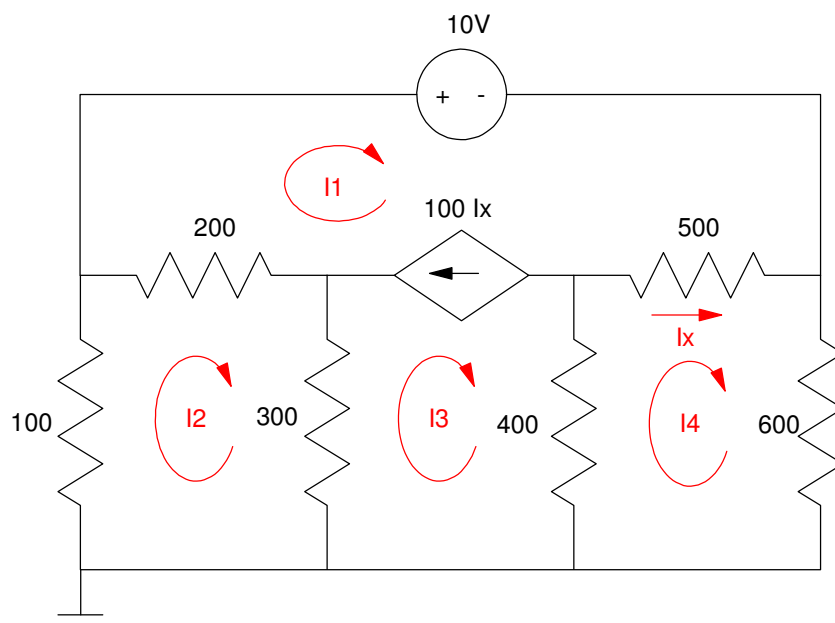

4) For the following circuit, the voltage at V3 is measured as 10V. Determine the voltages V0, V1, V2

(hint: use voltage division)

V0	V1	V2	V3
			10.0V

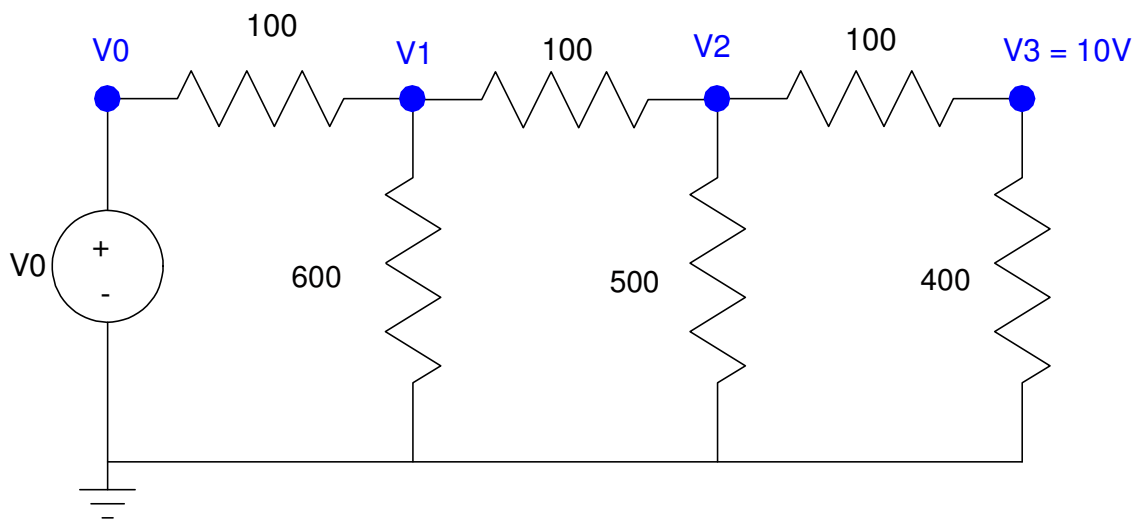

5) Given the voltages, determine the loop currents

I1	I2	I3	I4	I5

