

EE 206 Test #2c - Name _____

Thevenin Equivalents - Max Power Transfer - Superposition - Operational Amplifiers. April 22-23, 2019

1) Determine the Thevenin equivalent for the following circuit.

Vth	Rth

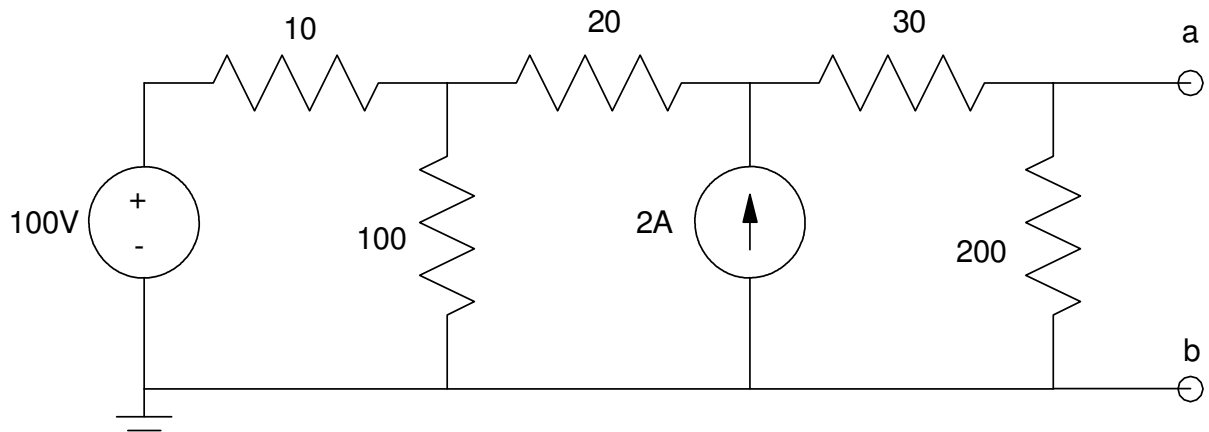

2) Determine the Thevenin equivalent for the following circuit

Vth	Rth

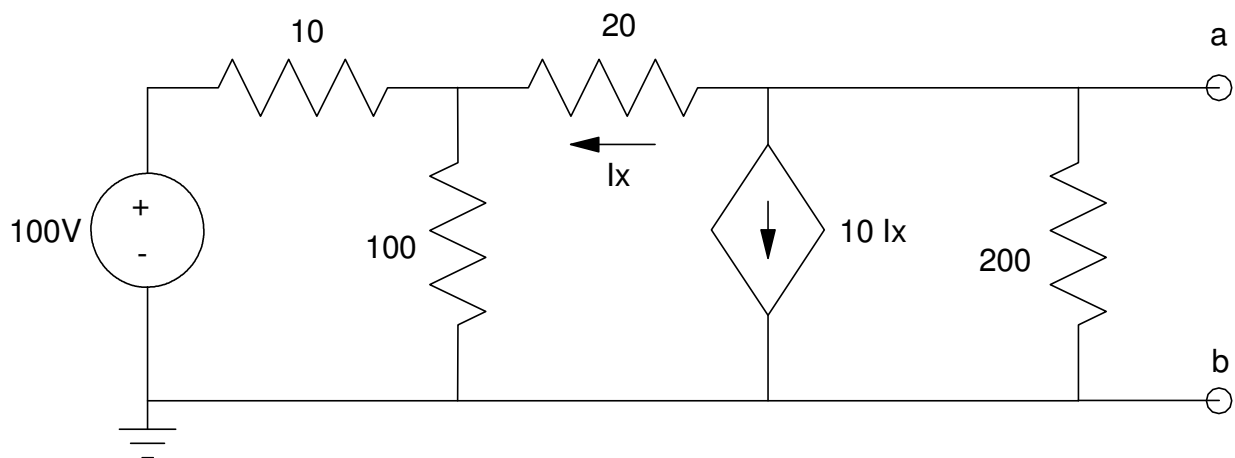

3) The voltage and current for a circuit is measured as the resistance changes.

R	12.2 Ohms	69.8 Ohms	326.5 Ohms
V	1.0 V	4.0 V	8.0 V
I	81.8 mA	57.3 mA	24.5 mA

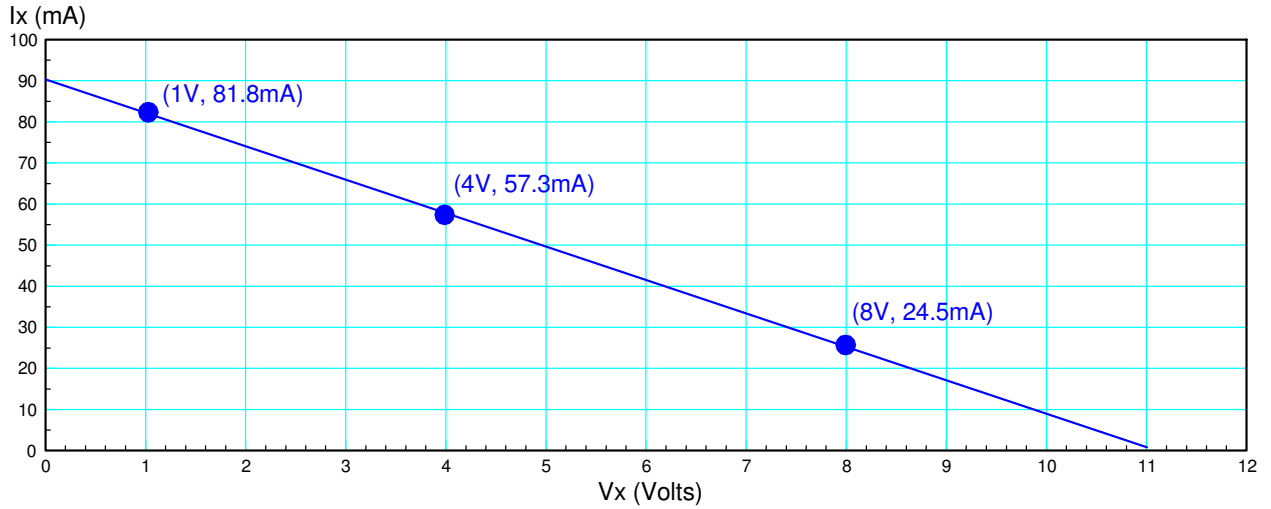

From this data, determine the Thevenin equivalent and the maximum power you can get out of this circuit.

Vth	Rth	R for maximum power transfer	Max power to R

4) Find the voltage at Y as a function of A and B

$$Y = aA + bB + c$$

a	b	c

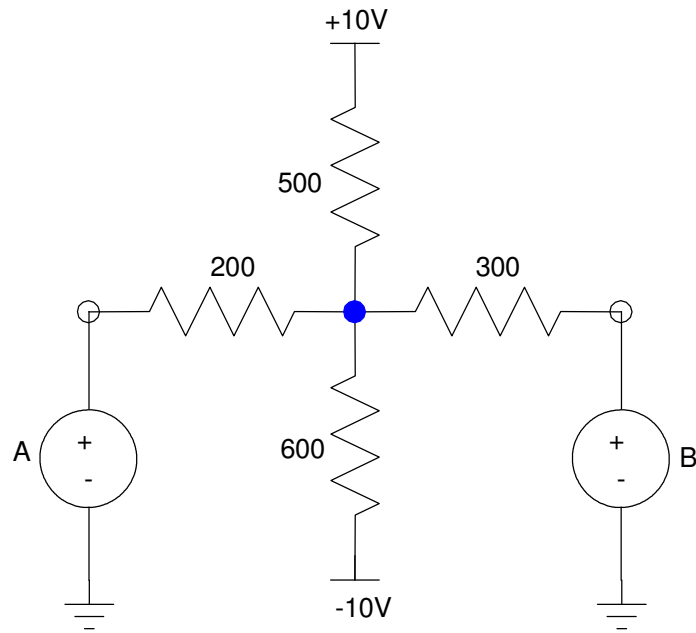

5) Determine the voltages V1, V2, V3, V4. Assume ideal op-amps.

V1	V2	V3	V4	V5

