

# EE 206 Test #1 - Name \_\_\_\_\_

February 19, 2020

1) Kirchoff's Laws. Determine the unknown voltages

V1	V2	V3	V4
<b>25 V</b>	<b>20 V</b>	<b>15 V</b>	<b>10 V</b>

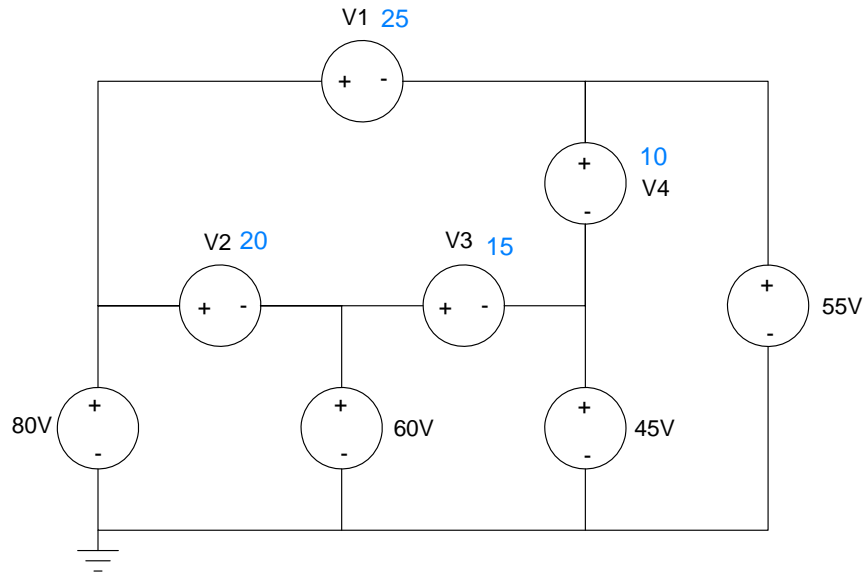

Determine the unknown currents

I1	I2	I3	I4
<b>20A</b>	<b>15A</b>	<b>10A</b>	<b>12A</b>

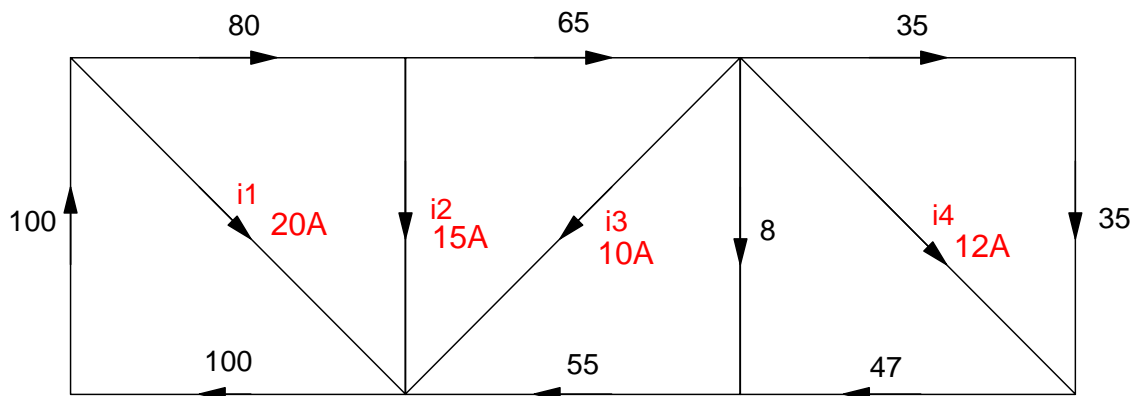

2) Determine the resistance Rab

$$R_{ab} = 1171.43$$

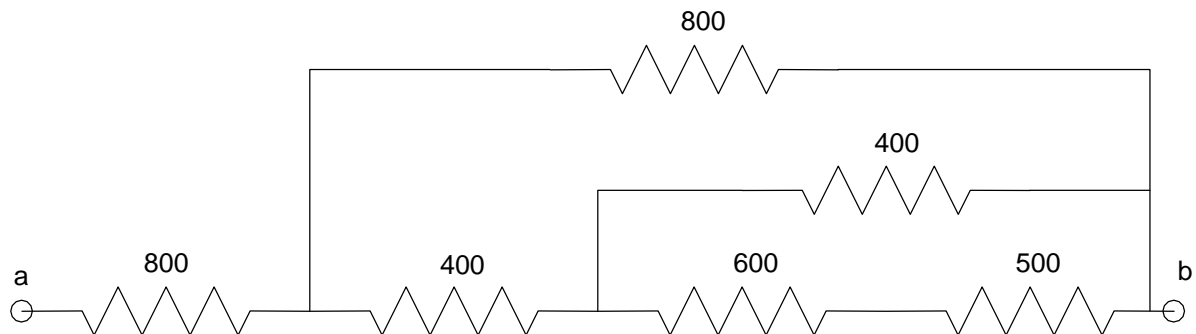

$$500 + 600 = 1100$$

$$1100 \parallel 400 = 293.33$$

$$293.33 + 400 = 693.33$$

$$693.33 \parallel 800 = 371.43$$

$$371.43 + 800 = 1171.43$$

3) Voltage Division. Use voltage division to determine the voltages V1 .. V3

V0	V1	V2	V3
<b>100.0V</b>	<b>38.46 V</b>	<b>15.38 V</b>	<b>7.69 V</b>

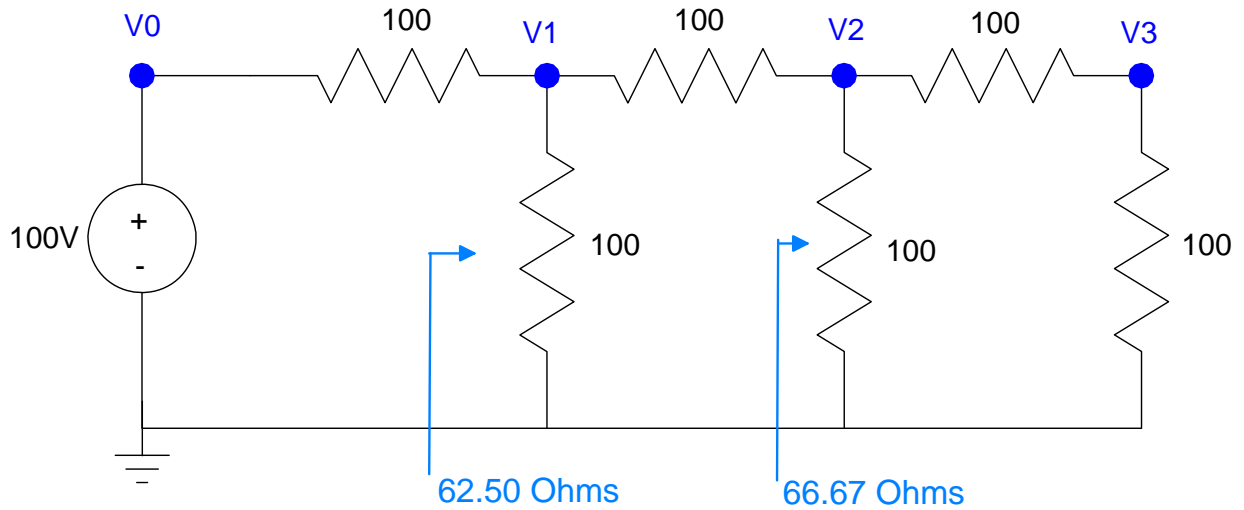

Determine the net resistance looking right at V1 and V2

By voltage division

$$V_1 = \left( \frac{62.50}{62.50+100} \right) 100V = 38.46V$$

$$V_2 = \left( \frac{66.67}{66.67+100} \right) V_1 = 15.38V$$

$$V_3 = \left( \frac{100}{100+100} \right) V_2 = 7.69V$$

4) Current Division. Determine the currents  $I_1 \dots I_4$

$I_1$	$I_2$	$I_3$	$I_4$
<b>44.44A</b>	<b>14.81A</b>	<b>40.74A</b>	<b>59.26A</b>

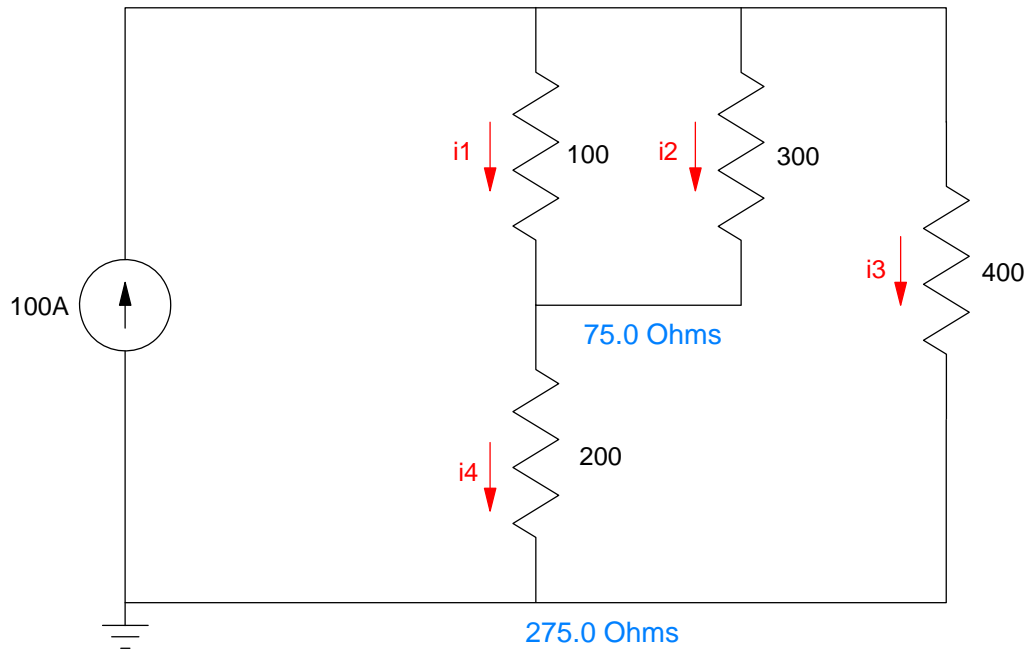

Determine the net resistance.

$$I_3 = \left( \frac{\left( \frac{1}{400} \right)}{\left( \frac{1}{400} \right) + \left( \frac{1}{275} \right)} \right) 100A = 40.74A$$

$$I_4 = \left( \frac{\left( \frac{1}{275} \right)}{\left( \frac{1}{400} \right) + \left( \frac{1}{275} \right)} \right) 100A = 59.26A$$

$$I_1 = \left( \frac{\left( \frac{1}{100} \right)}{\left( \frac{1}{100} \right) + \left( \frac{1}{300} \right)} \right) I_4 = 44.44A$$

$$I_2 = \left( \frac{\left( \frac{1}{300} \right)}{\left( \frac{1}{100} \right) + \left( \frac{1}{300} \right)} \right) I_4 = 14.81A$$

5) Voltage Nodes: Write 5 equations to solve for the 5 unknowns.

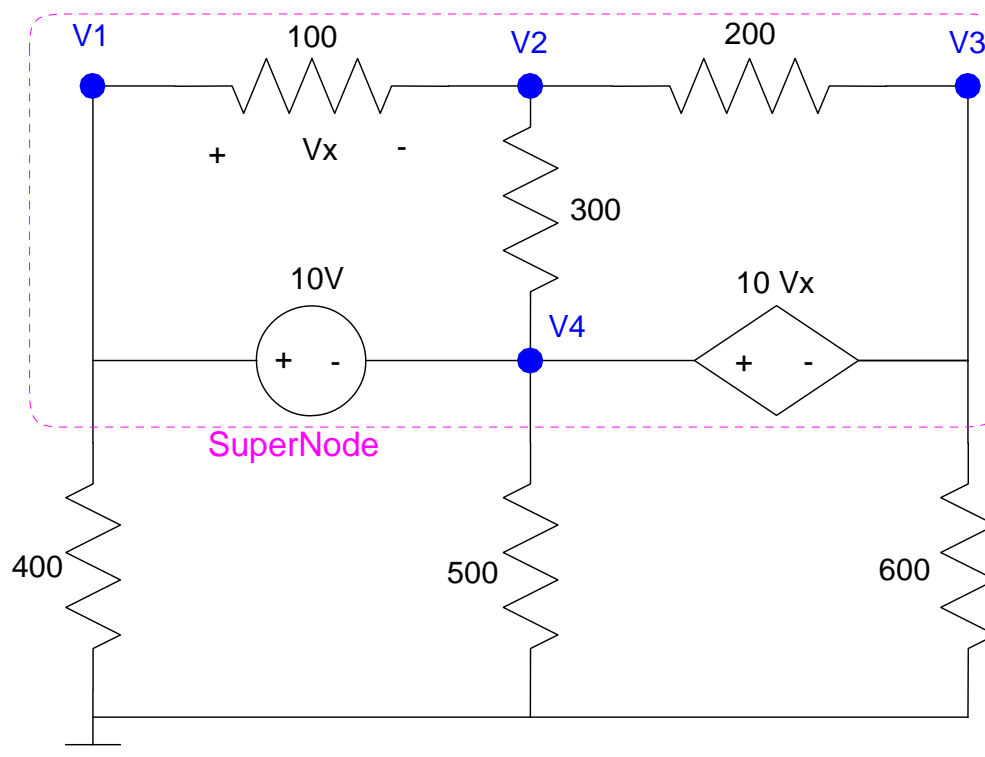

$$V_x = V_1 - V_2$$

$$V_1 - V_4 = 10$$

$$V_4 - V_3 = 10 \cdot V_x$$

$$\left(\frac{V_2 - V_1}{100}\right) + \left(\frac{V_2 - V_4}{300}\right) + \left(\frac{V_2 - V_3}{200}\right) = 0$$

$$\left(\frac{V_1}{400}\right) + \left(\frac{V_4}{500}\right) + \left(\frac{V_3}{600}\right) = 0$$

6) Current Loops. Write 5 equations to solve for 5 unknowns

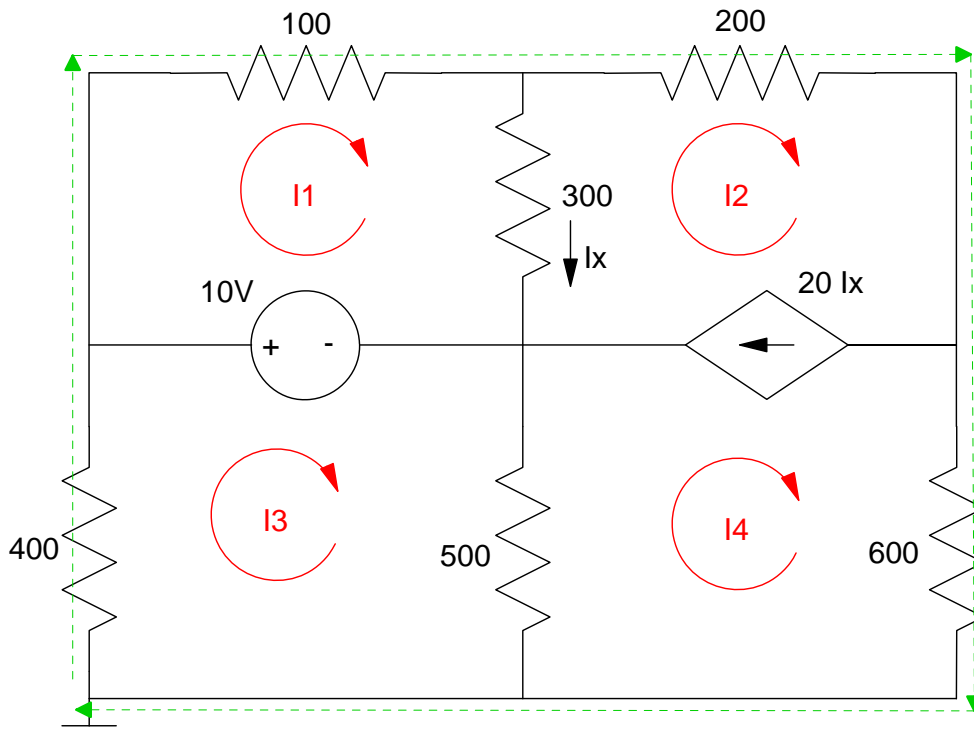

$$I_x = I_1 - I_2$$

$$I_2 - I_4 = 20I_x$$

Loop I3

$$400I_3 + 10 + 500(I_3 - I_4) = 0$$

Loop I1

$$100I_1 + 300(I_1 - I_2) - 10 = 0$$

Super Loop

$$400I_3 + 100I_1 + 200I_2 + 600I_4 = 0$$

**Green New Deal Bonus!** The best solar panels are 21% efficient. How efficient is photosynthesis?

- Sugar Cane: 8%
- Food Crops: 1% to 2%
- Most Plants: 0.1% to 0.2%

Photosynthesis only uses blue and red light - which limits the theoretical maximum efficiency to 11% (wikipedia)

Solar cells can't use photons whose energy is less than the energy gap of silicon. Excess energy is also lost, making the maximum theoretical efficiency 68.7% (wikipedia)