

# ECE 311 - Solution to Homework #2

EE 206 Review, Phasors. Due Monday, August 27th, 2018

## 1. Voltage Nodes:

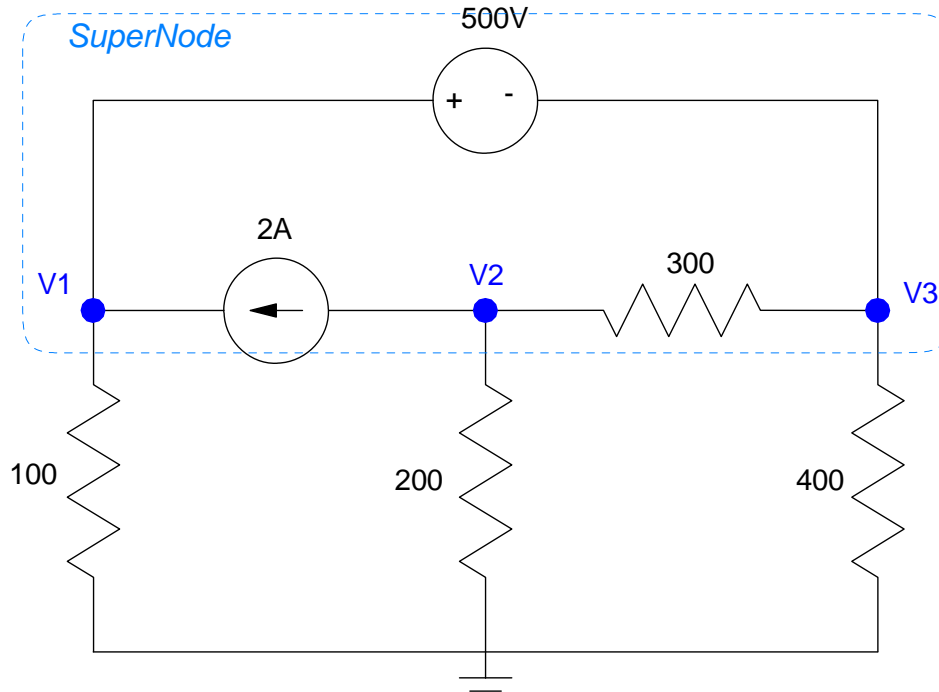

a) Write the voltage node equations. You have 3 voltage nodes, so you need 3 equations to solve for 3 unknowns. Start with the easy one (the voltage source)

$$V_1 - V_3 = 500 \quad (1)$$

Sum the current from node V2 to zero:

$$2 + \left(\frac{V_2}{200}\right) + \left(\frac{V_2 - V_3}{300}\right) = 0 \quad (2)$$

We need one more equation. Define a supernode (shown in blue dashes - other definitions are also valid). Sum the current from the super-node to zero.

$$\left(\frac{V_1}{100}\right) + \left(\frac{V_2}{200}\right) + \left(\frac{V_3}{400}\right) = 0 \quad (3)$$

b) Solve using Matlab (or similar program) Group terms

$$V_1 - V_3 = 500$$

$$\left(\frac{1}{200} + \frac{1}{300}\right)V_2 - \left(\frac{1}{300}\right)V_3 = -2$$

$$\left(\frac{1}{100}\right)V_1 + \left(\frac{1}{200}\right)V_2 + \left(\frac{1}{400}\right)V_3 = 0$$

Place in matrix form

$$\begin{bmatrix} 1 & 0 & -1 \\ 0 & \left(\frac{1}{200} + \frac{1}{300}\right) & \left(\frac{-1}{300}\right) \\ \left(\frac{1}{100}\right) & \left(\frac{1}{200}\right) & \left(\frac{1}{400}\right) \end{bmatrix} \begin{bmatrix} V_1 \\ V_2 \\ V_3 \end{bmatrix} = \begin{bmatrix} 500 \\ -2 \\ 0 \end{bmatrix}$$

Solve using Matlab

```
>> A = [1,0,-1 ; 0,1/200+1/300,-1/300 ; 1/100, 1/200, 1/400]
```

```
    1.0000         0   -1.0000
         0    0.0083  -0.0033
    0.0100    0.0050    0.0025
```

```
>> B = [500 ; -2 ; 0]
```

```
    500
     -2
         0
```

```
>> V = inv(A)*B
```

```
    237.9310
   -344.8276
   -262.0690
```

c) Check your answers in PartSim (or similar circuit simulator)

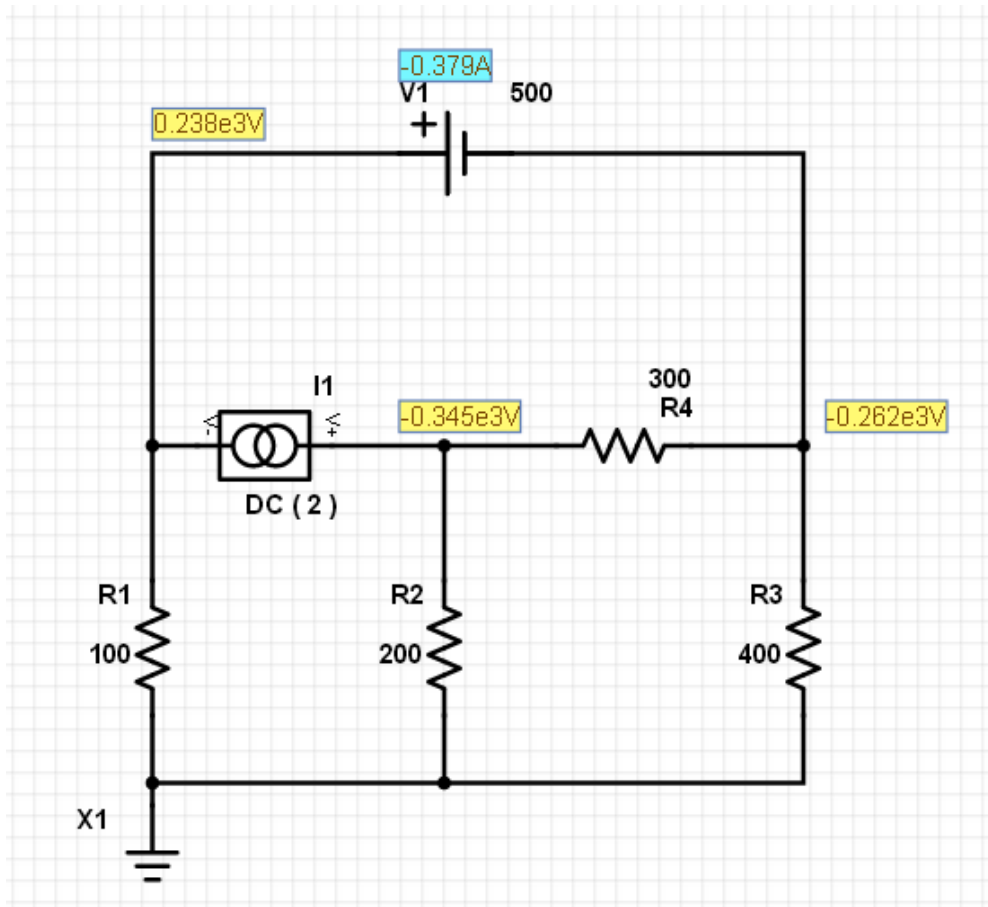

## 2. Current Loops:

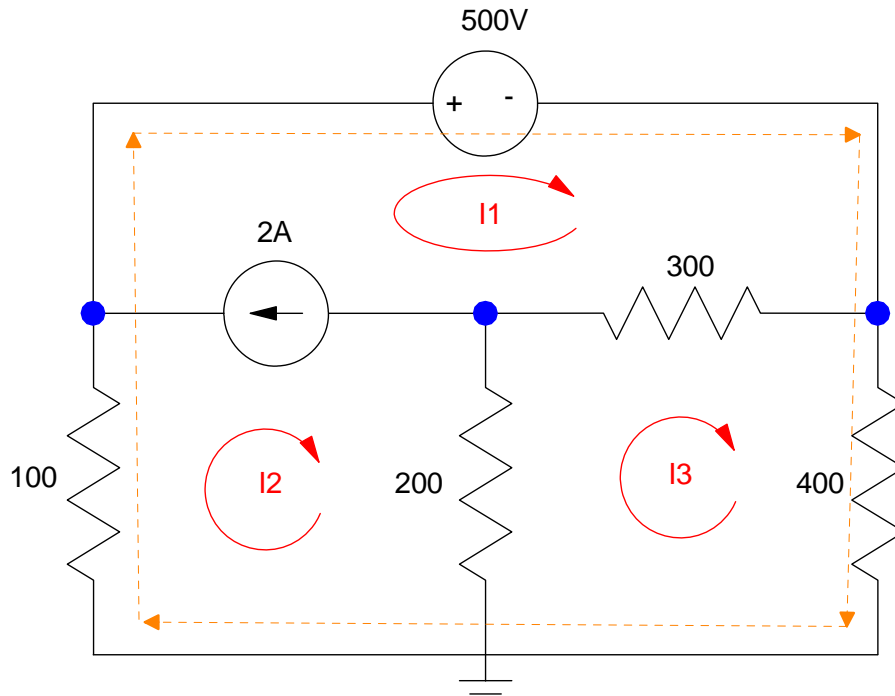

**a) Write the current loop equations.** There are three windows (unknown currents). We need to write 3 equations to solve for 3 unknowns. Start with the easy one (the current source)

$$I_1 - I_2 = 2 \quad (1)$$

Sum the voltage around loop I3 to zero

$$200(I_3 - I_2) + 300(I_3 - I_1) + 400I_3 = 0 \quad (2)$$

For the 3rd equation, take some other path that avoids the current source (super loop shown in orange. There are other options)

$$100I_2 + 500 + 400I_3 = 0 \quad (3)$$

**b) Solve using Matlab (or similar program)** Group terms

$$I_1 - I_2 = 2$$

$$-300I_1 - 200I_2 + 900I_3 = 0$$

$$100I_2 + 400I_3 = -500$$

Place in matrix form

$$\begin{bmatrix} 1 & -1 & 0 \\ -300 & -200 & 900 \\ 0 & 100 & 400 \end{bmatrix} \begin{bmatrix} I_1 \\ I_2 \\ I_3 \end{bmatrix} = \begin{bmatrix} 2 \\ 0 \\ -500 \end{bmatrix}$$

Solve with Matlab

```
>> A = [1,-1,0 ; -300,-200,900 ; 0,100,400]
```

```
    1    -1     0
-300  -200   900
    0   100   400
```

```
>> B = [2 ; 0 ; -500]
```

```
    2
    0
-500
```

```
>> I = inv(A)*B
```

```
I1   -0.3793
I2   -2.3793
I3   -0.6552
```

Check: Compute the voltage V1:

```
>> -I(2)*100
```

```
237.9310
```

This matches PartSim

### 3. Voltage Nodes:

a) Write the voltage node equations for the following circuit

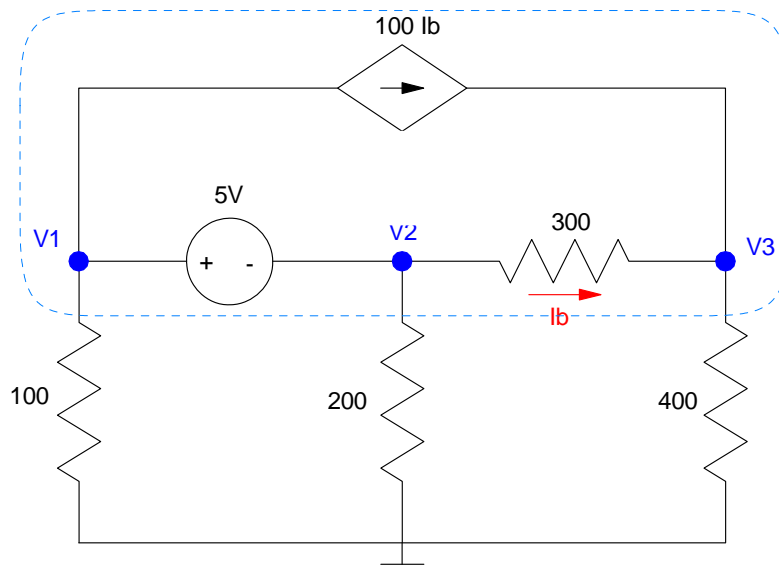

First define  $I_b$  in terms of the voltages

$$I_b = \left( \frac{V_2 - V_3}{300} \right) \quad (1)$$

Write the voltage source equation

$$V_1 - V_2 = 5 \quad (2)$$

Write the node equations at V3

$$\left( \frac{V_3 - V_2}{300} \right) + \left( \frac{V_3}{400} \right) - 100I_b = 0 \quad (3)$$

Supernode (shown in dotted line - other supernodes can be used as well)

$$\left( \frac{V_1}{100} \right) + \left( \frac{V_2}{200} \right) + \left( \frac{V_3}{400} \right) = 0 \quad (4)$$

Solve using Matlab (or similar program). Group terms

$$\left( \frac{-1}{300} \right) V_2 + \left( \frac{1}{300} \right) V_3 + I_b = 0$$

$$V_1 - V_2 = 5$$

$$\left( \frac{-1}{300} \right) V_2 + \left( \frac{1}{300} + \frac{1}{400} \right) V_3 - 100I_b = 0$$

$$\left( \frac{V_1}{100} \right) + \left( \frac{V_2}{200} \right) + \left( \frac{V_3}{400} \right) = 0$$

Place in matrix form

$$\begin{bmatrix} 0 & \left(\frac{-1}{300}\right) & \left(\frac{1}{300}\right) & 1 \\ 1 & -1 & 0 & 0 \\ 0 & \left(\frac{-1}{300}\right) & \left(\frac{1}{300} + \frac{1}{400}\right) & -100 \\ \left(\frac{1}{100}\right) & \left(\frac{1}{200}\right) & \left(\frac{1}{400}\right) & 0 \end{bmatrix} \begin{bmatrix} V_1 \\ V_2 \\ V_3 \\ I_b \end{bmatrix} = \begin{bmatrix} 0 \\ 5 \\ 0 \\ 0 \end{bmatrix}$$

Solve with Matlab

```
>> A = [0,-1/300,1/300,1 ; 1,-1,0,0 ; 0,-1/300,1/300+1/400,-100 ; 1/100,1/200,1/400,0]
```

```
      0    -0.0033    0.0033    1.0000
  1.0000   -1.0000         0         0
      0    -0.0033    0.0058  -100.0000
  0.0100    0.0050    0.0025         0
```

```
>> B = [0;5;0;0]
```

```
      0
      5
      0
      0
```

```
>> V= inv(A)*B
```

```
V1    2.1398
V2   -2.8602
V3   -2.8391
Ib   -0.0001
```

#### 4. Current Loops:

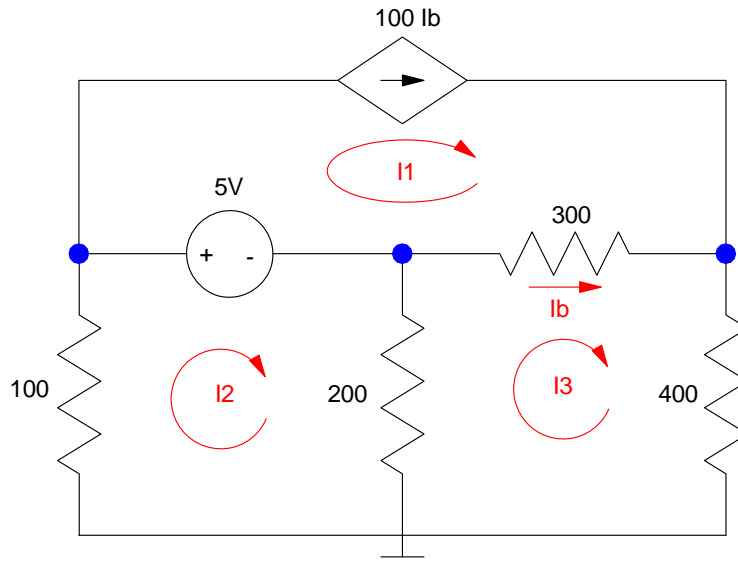

Problem 3 & 4

a) Write the current loop equations for the following circuit

$$I_b = I_3 - I_1$$

$$I_1 = 100I_b$$

$$100I_2 + 5 + 200(I_2 - I_3) = 0$$

$$200(I_3 - I_2) + 300(I_3 - I_1) + 400I_3 = 0$$

b) Solve using Matlab (or similar program). Group terms

$$I_b - I_3 + I_1 = 0$$

$$I_1 - 100I_b = 0$$

$$300I_2 - 200I_3 = -5$$

$$-300I_1 - 200I_2 + 900I_3 = 0$$

Place in matrix form

$$\begin{bmatrix} 1 & 0 & -1 & 1 \\ 1 & 0 & 0 & -100 \\ 0 & 300 & -200 & 0 \\ -300 & -200 & 900 & 0 \end{bmatrix} \begin{bmatrix} I_1 \\ I_2 \\ I_3 \\ I_b \end{bmatrix} = \begin{bmatrix} 0 \\ 0 \\ -5 \\ 0 \end{bmatrix}$$

Solve with matlab

```
>> A = [1,0,-1,1 ; 1,0,0,-100 ; 0,300,-200,0 ; -300,-200,900,0]
```

```

1     0     -1     1
1     0     0    -100
0    300    -200     0
-300  -200    900     0
```

```
>> B = [0;0;-5;0]
```

```
0  
0  
-5  
0
```

```
>> I = inv(A)*B
```

```
I1 -0.0070  
I2 -0.0214  
I3 -0.0071  
Ib -0.0001
```



5) Assume  $V_{in}$  contains a DC and 16Hz (100 rad/sec) signal:

$$V_{in} = 5 + 3 \sin(100t)$$

a) Determine the impedances of the inductor, capacitor, and resistor at DC and 100 rad/sec

DC (blue)

$$\omega = 0$$

$$L \rightarrow j\omega L = 0$$

$$C \rightarrow \frac{1}{j\omega C} = \infty$$

AC (red)

$$\omega = 100$$

$$L \rightarrow j\omega L = j10$$

$$C \rightarrow \frac{1}{j\omega C} = -j1000$$

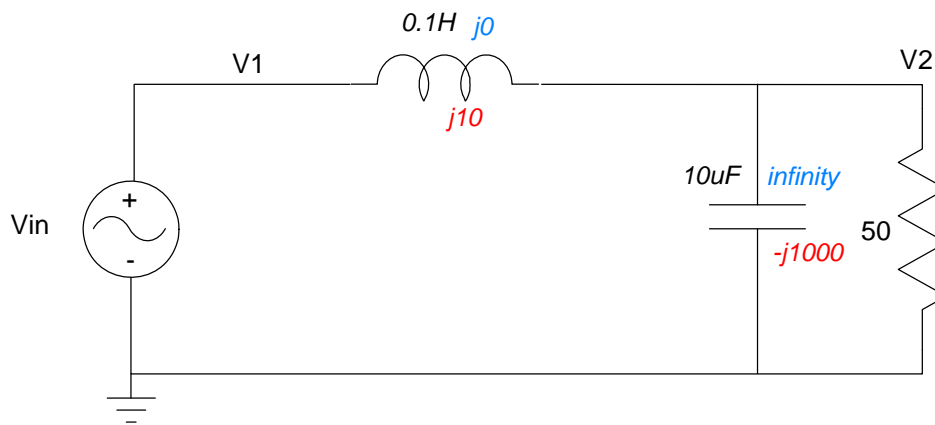

b) Determine the voltage,  $V_2$ , using phasor analysis

Voltage node equation

DC

$$V_{in} = 5$$

$$V_2 = V_{in} = 5$$

AC

$$V_{in} = -j3$$

$$\left( \frac{V_2 - V_{in}}{j10} \right) + \left( \frac{V_2}{-j1000} \right) + \left( \frac{V_2}{50} \right) = 0$$

$$V_2 = 2.97 \angle -101^\circ \quad (\text{polar form})$$

$$v_2(t) = 2.97 \cos(100t - 101^\circ)$$

$$V_2 = -0.567 - j2.915 \quad (\text{rectangular form})$$

$$v_2(t) = -5.67 \cos(100t) + 2.915 \sin(100t)$$

Total answer: DC + AC

$$v_2(t) = 10 + 2.97 \cos(100t - 101^\circ)$$

$$v_2(t) = 5 - 5.67 \cos(100t) + 2.915 \sin(100t)$$

c) Check your answer using PartSim (or similar program)

Input the circuit in PartSim. Use a transient input (sinusoid) with a

- 10V DC offset
- 3V AC amplitude
- 15.915Hz (100 rad/sec)

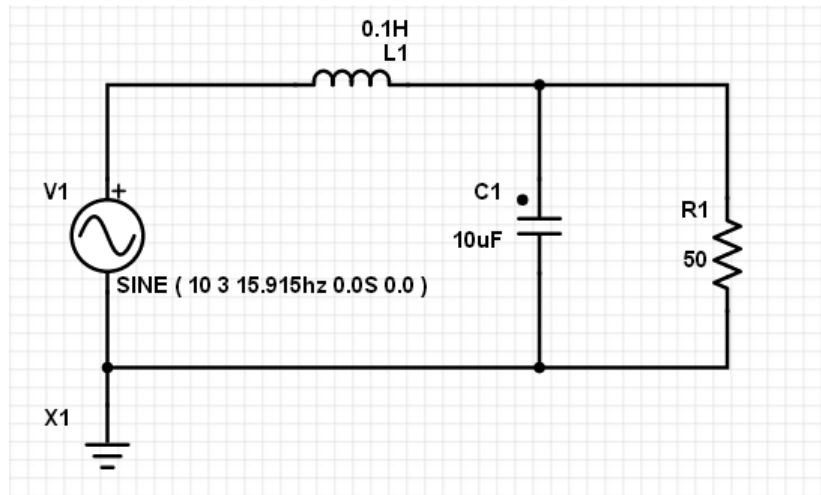

Run a transient simulation for several cycles

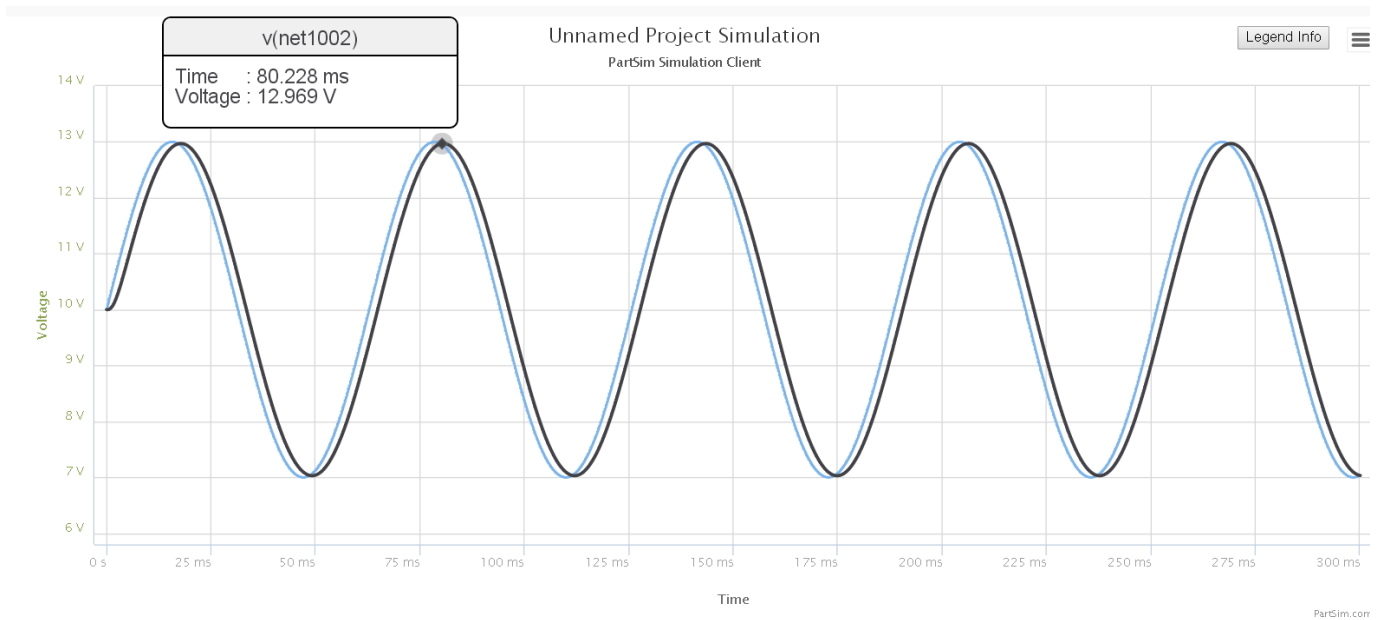

The DC signal at the output (black) is 10V

The AC signal is 2.969Vp (vs. 2.97Vp computed)

The AC signal has a small delay (-10 degrees computed)

6) Assume  $V_{in}$  contains a DC and 160Hz signal:

$$V_{in} = 5 + 3 \sin(1000t)$$

a) Determine the impedances of the inductor, capacitor, and resistor at DC and 1000 rad/sec

DC

AC (1000 rad/sec)

no change

$$\omega = 1000$$

$$L = 0$$

$$L \rightarrow j\omega L = j100$$

$C = \text{infinity}$

$$C \rightarrow \frac{1}{j\omega C} = -j100$$

$$V_{in} = -j3$$

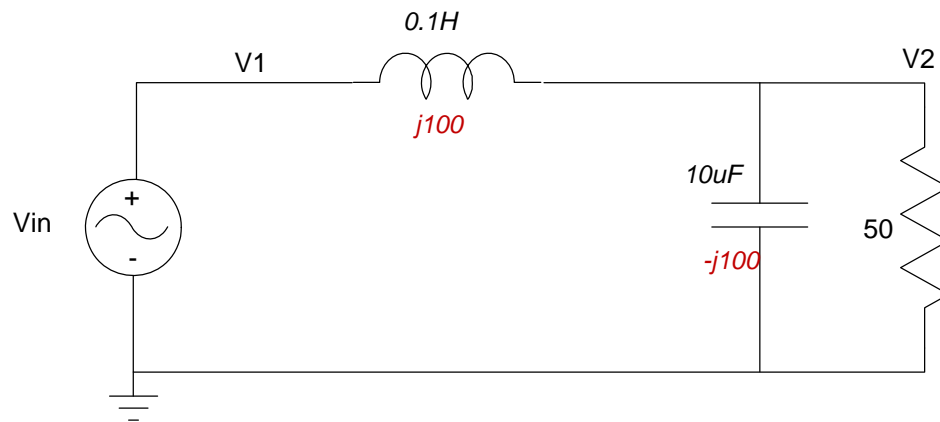

b) Determine the voltage,  $V_2$ , using phasor analysis

DC

AC

$$V_2 = V_1 = 5$$

$$50 \parallel -j100 = 40 - j20$$

$$V_2 = \left( \frac{40 - j20}{(40 - j20) + j100} \right) (0 - j3)$$

$$V_2 = 1.5 \angle 180^\circ$$

$$v_2(t) = 1.5 \cos(1000t + 180^\circ)$$

Total answer: DC + AC

$$v_2(t) = 5 + 1.5 \cos(1000t + 180^\circ)$$

Checking in PartSim (not required)

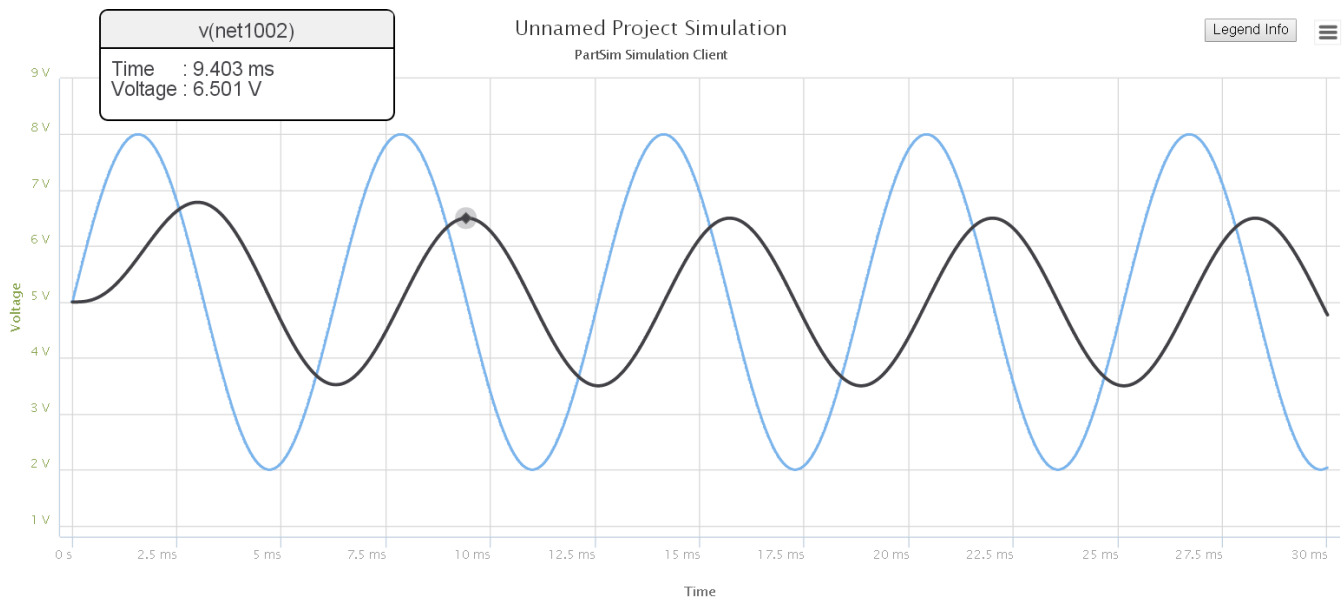
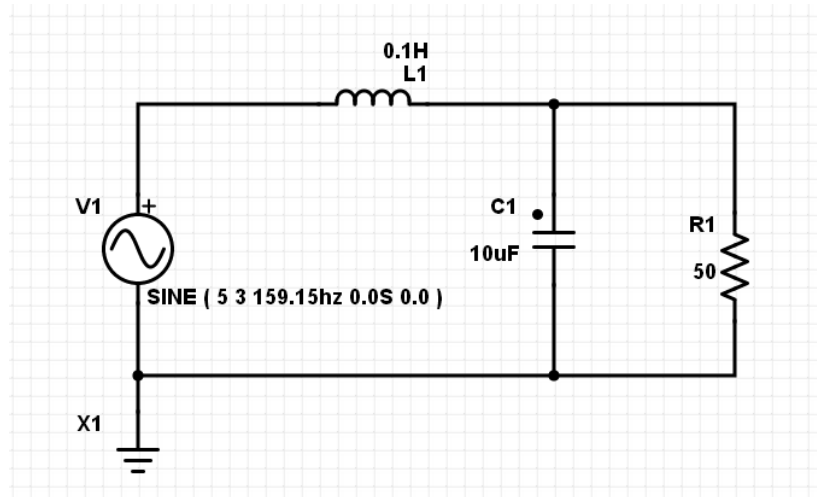

DC level = 5V (vs. 5.00V computed)

AC = 1.501Vp ( vs. 1.50V computed)

Output is delayed by 90 degrees (vs. 90 degrees computed)