

# ECE 320 - Homework #1

EE 206 Review, Phasors. Due Monday, August 30th

Please submit as a Word or pdf file if submitting on Blackboard or emailing to Jacob\_Glower@yahoo.com with subject ECE 320 HW#1

## Resistors in series and parallel

1) Assume  $X = \text{infinity}$  (DC analysis). Determine the resistance  $R_{ab}$

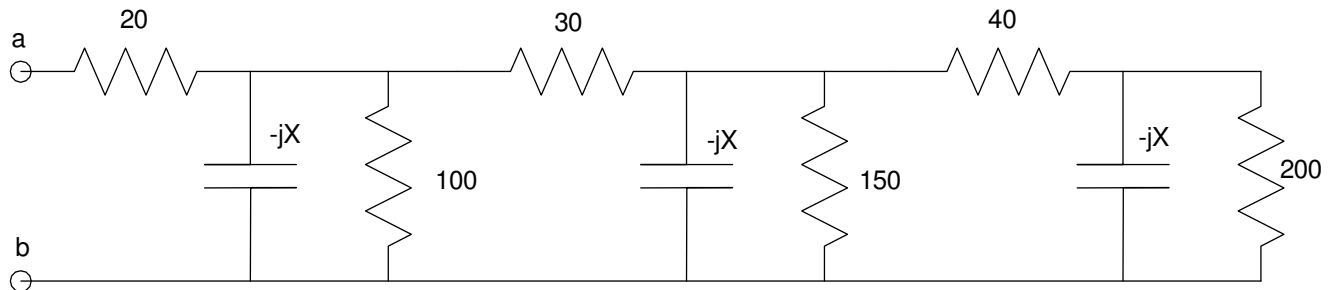

$$200 + 40 = 240$$

$$240 \parallel 150 = 92.3077$$

$$92.3077 + 30 = 122.3077$$

$$122.3077 \parallel 100 = 55.0173$$

$$55.0173 + 20 = 75.0173$$

**ans:  $R_{ab} = 75.0173$  Ohms**

2) Assume  $-jX = -j250$ . Determine the resistance  $R_{ab}$  (it will be a complex number)

$$200 \parallel -j250 = 121.951 - j97.561$$

$$(121.951 - j97.561) + (40) = 161.951 - j97.561$$

$$(161.951 - j97.561) \parallel (150) \parallel (-j250) = 65.611 - j39.431$$

$$(65.611 - j39.431) + (30) = 95.611 - j39.431$$

$$(95.611 - j39.431) \parallel (100) \parallel (-j250) = 45.334 - j18.399$$

$$(45.334 - j18.399) + (20) = 65.334 - j18.339$$

**ans:  $R_{ab} = 65.334 - j18.339$  Ohms**

## Voltage Nodes & Current Loops

3) (Voltage Nodes): For the following circuit

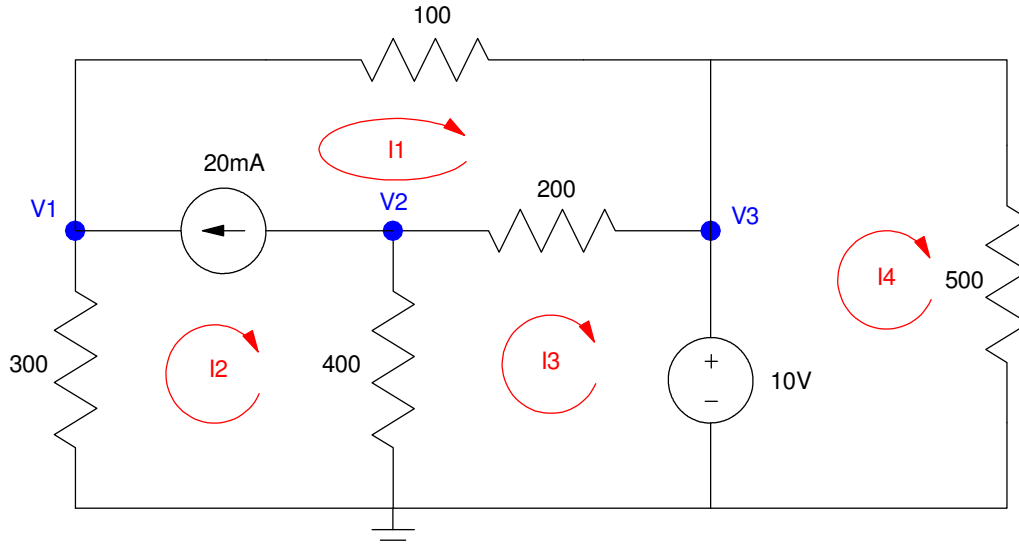

a) Write the voltage node equations

$$V_3 = 10$$

$$\left(\frac{V_1 - V_3}{100}\right) - 0.02 + \left(\frac{V_1}{300}\right) = 0$$

$$0.02 + \left(\frac{V_2}{400}\right) + \left(\frac{V_2 - V_3}{200}\right) = 0$$

b) Solve using Matlab (or similar program)

group terms

$$V_3 = 10$$

$$\left(\frac{1}{100} + \frac{1}{300}\right)V_1 - \left(\frac{1}{100}\right)V_3 = 0.02$$

$$\left(\frac{1}{400} + \frac{1}{200}\right)V_2 - \left(\frac{1}{200}\right)V_3 = -0.02$$

Put in matrix form

$$\begin{bmatrix} 0 & 0 & 1 \\ \left(\frac{1}{100} + \frac{1}{300}\right) & 0 & \left(\frac{-1}{100}\right) \\ 0 & \left(\frac{1}{400} + \frac{1}{200}\right) & \left(\frac{-1}{200}\right) \end{bmatrix} \begin{bmatrix} V_1 \\ V_2 \\ V_3 \end{bmatrix} = \begin{bmatrix} 10 \\ 0.02 \\ -0.02 \end{bmatrix}$$

### Solve using Matlab

```
>> A = [0,0,1 ; 1/100+1/300,0,-1/100 ; 0,1/400+1/200,-1/200]
```

A =

```
      0      0      1.0000
0.0133      0     -0.0100
      0     0.0075    -0.0050
```

```
>> B = [10;0.02;-0.02]
```

B =

```
10.0000
 0.0200
 -0.0200
```

```
>> V = inv(A)*B
```

V =

```
V1  9.0000
V2  4.0000
V3 10.0000
```

c) Check your answers in CircuitLab (or similar circuit simulator)

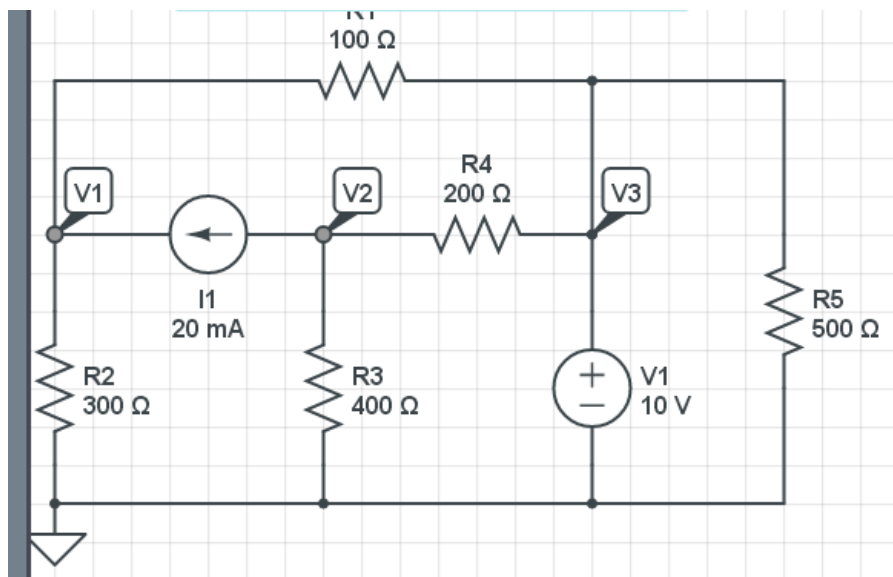
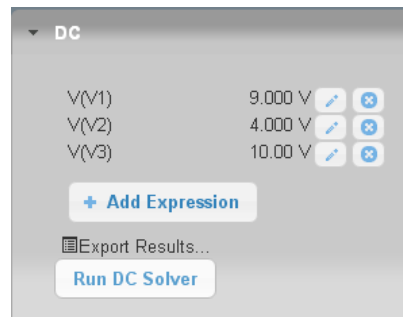

4) (Current Loops) For the following circuit

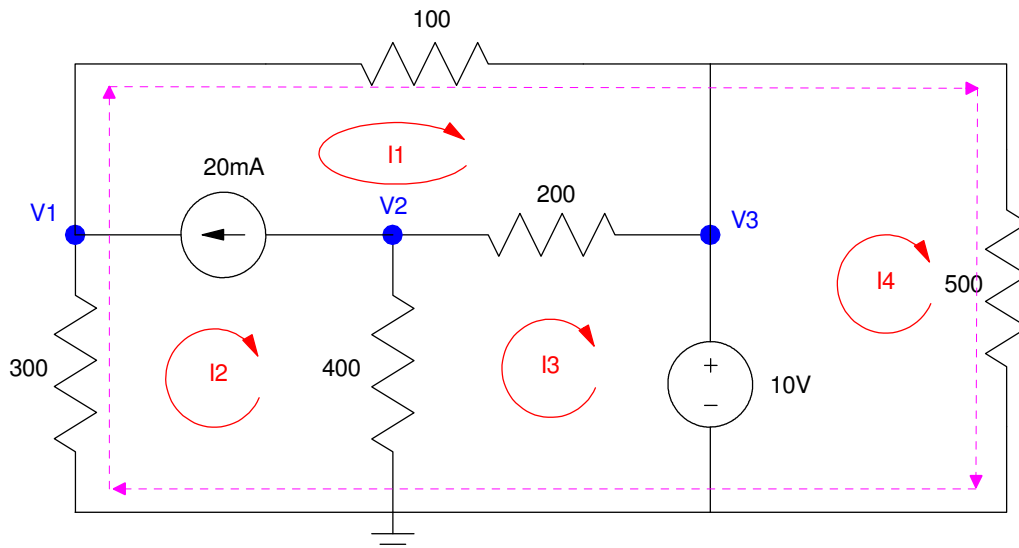

a) Write the current loop equations

$$I_1 - I_2 = 20mA$$

$$400(I_3 - I_2) + 200(I_3 - I_1) + 10 = 0$$

$$-10 + 500I_4 = 0$$

$$300I_2 + 100I_1 + 500I_4 = 0 \quad \text{superloop}$$

b) Solve using Matlab (or similar program)

group terms

$$I_1 - I_2 = 20mA$$

$$-200I_1 - 400I_2 + 600I_3 = -10$$

$$500I_4 = 10$$

$$300I_2 + 100I_1 + 500I_4 = 0$$

Place in matrix form

$$\begin{bmatrix} 1 & -1 & 0 & 0 \\ -200 & -400 & 600 & 0 \\ 0 & 0 & 0 & 500 \\ 100 & 300 & 0 & 500 \end{bmatrix} \begin{bmatrix} I_1 \\ I_2 \\ I_3 \\ I_4 \end{bmatrix} = \begin{bmatrix} 0.02 \\ -10 \\ 10 \\ 0 \end{bmatrix}$$

### Solve in Matlab

```
>> A = [1,-1,0,0 ; -200,-400,600,0 ; 0,0,0,500 ; 100,300,0,500]
```

```
    1    -1     0     0
 -200  -400   600     0
     0     0     0   500
    100   300     0   500
```

```
>> B = [0.02 ; -10 ; 10 ; 0]
```

```
    0.0200
 -10.0000
    10.0000
         0
```

```
>> I = inv(A)*B
```

```
I1   -0.0100
I2   -0.0300
I3   -0.0400
I4    0.0200
```

c) Check your answers in CircuitLab (or similar circuit simulator)

note:  $I(R3) = I3 - I2 = -10\text{mA}$

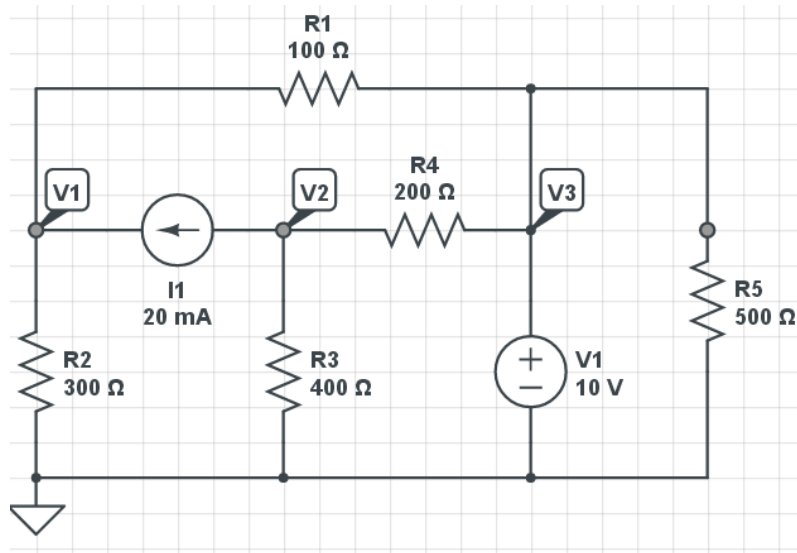
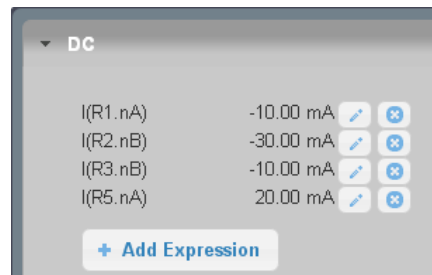

5) Assume  $V_{in}$  contains a DC and 500 rad/sec signal:

$$V_{in} = 10 + 2 \cos(500t) + 6 \sin(500t)$$

a) Determine the voltage,  $V_2$ , using phasor analysis

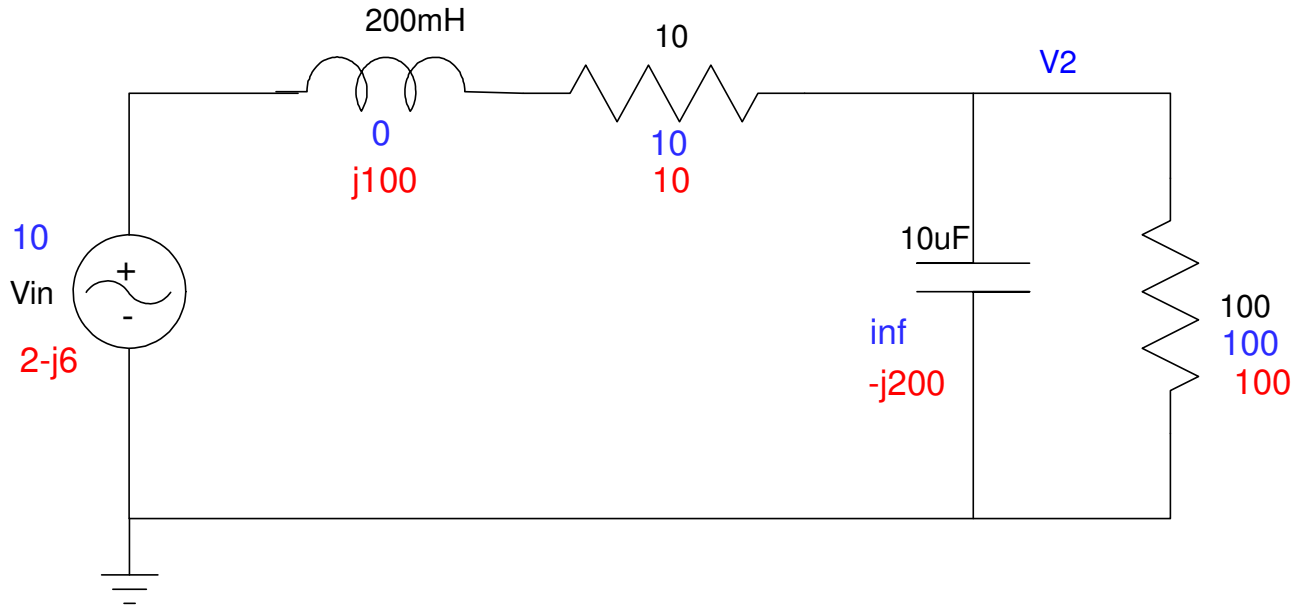

DC Analysis (blue)

$$V_{in} = 10$$

$$V_2 = \left( \frac{100}{100+10} \right) 10 = 9.091V$$

meaning  $V_2(t) = 9.091$

AC Analysis (red)

$$V_{in} = 2 - j6$$

$$L \rightarrow j\omega L = j100$$

$$C \rightarrow \frac{1}{j\omega C} = -j200$$

$$100 \parallel -j200 = 80 - j40$$

$$\left( \frac{(80-j40)}{(80-j40)+(10+j100)} \right) (2 - j6) = -3.487 - j3.897$$

meaning  $V_2(t) = -3.487 \cos(500t) + 3.897 \sin(500t)$

The total answer is DC + AC

**ans**  $V_2(t) = 9.091 - 3.487 \cos(500t) + 3.897 \sin(500t)$

b) Check your answer using CircuitLab (or similar program)

500 rad/sec = 79.58Hz

$$\omega = 2\pi f$$

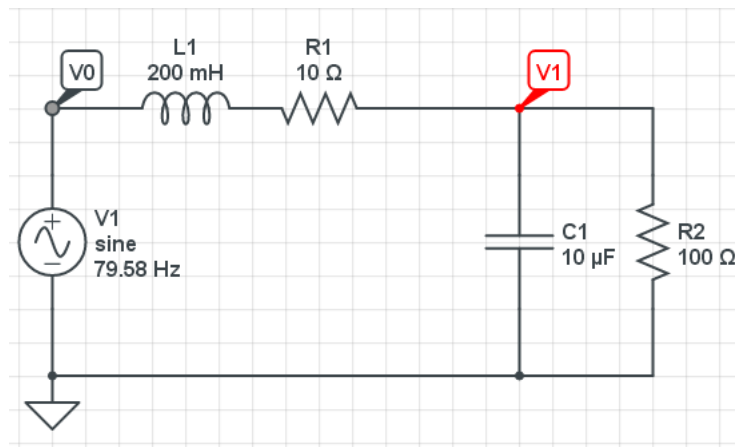

Running a time domain simulation for 3 cycles

- The output (orange) has a peak-to-peak voltage of 10V (vs. 10.46Vpp calculated)  
 $2 * |-3.487 - j 3.897| = V_{pp} = 10.46V_{pp}$
- The output (orange) has an average voltage of 9.2V (vs 9.091V)

