

ECE 321 - Homework #4

CE / CC / CB Amplifiers. Due Monday, May 1st, 2017

Assume $\beta = 100$. From homework set #3, the Q point for the circuit below is

- $V_{ce} = 6V$
- $I_c = 1.2mA$

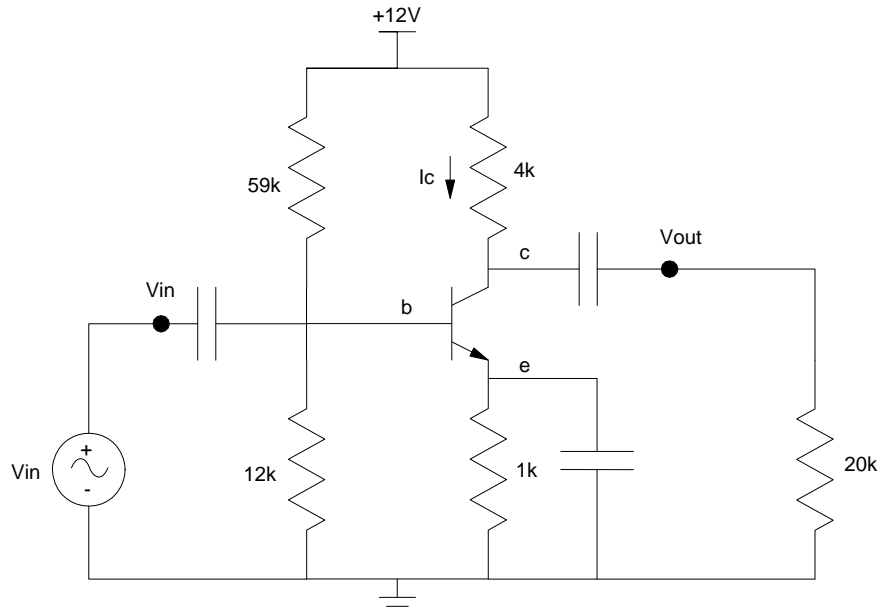

1) Common Emitter Amplifier:

1a) Draw the small circuit equivalent for this circuit configured as a common emitter amplifier driving a 20k load (shown above)

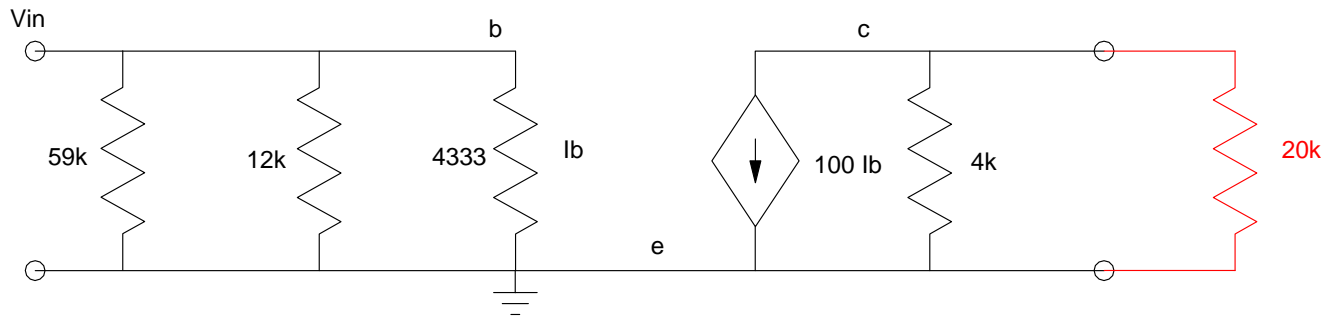

1b) Determine the 2-port model for this amplifier.

$$R_{in} = 59k || 12k || 4330 = 3020$$

$$A_i = 0$$

$$R_{out} = 4k$$

$$A_o = -\frac{\beta \cdot 4k}{4333} = -92.3$$

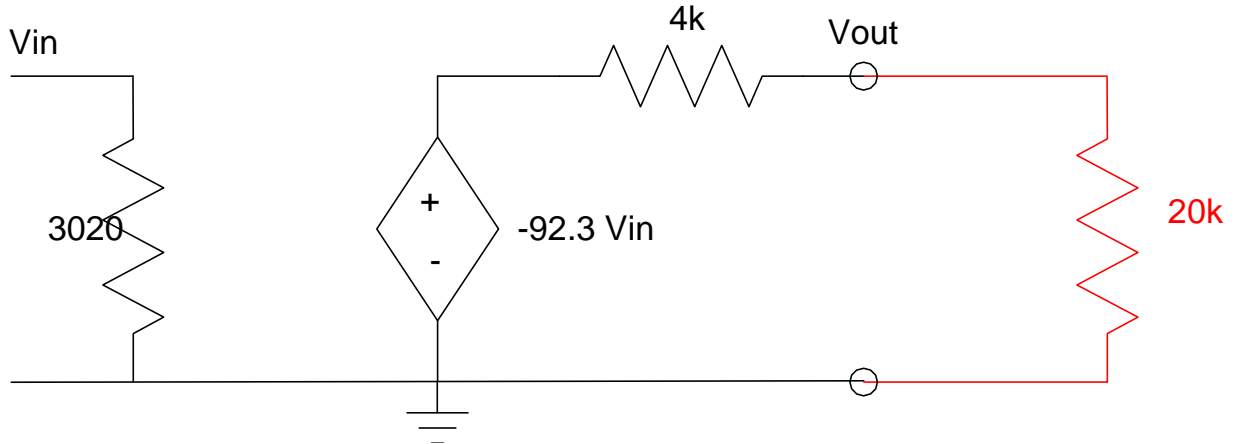

2) Common Base Amplifier:

2a) Draw the small circuit equivalent for this circuit configured as a common base amplifier driving a 20k load

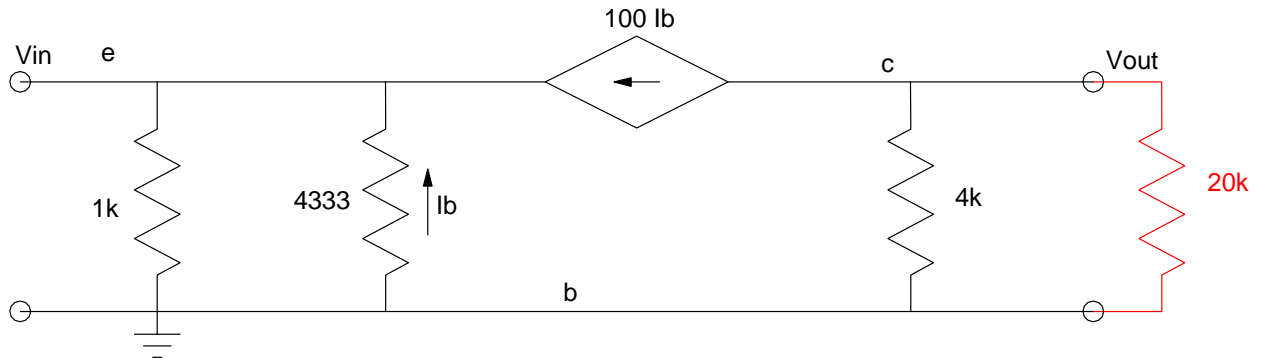

2b) Determine the 2-port model for this amplifier.

$$R_{in} = 1k || 4333 || \frac{4333}{100} = 41.1$$

$$A_i = 0$$

$$R_{out} = 4k$$

$$A_o = \frac{\beta R_c}{r_f} = +92.1$$

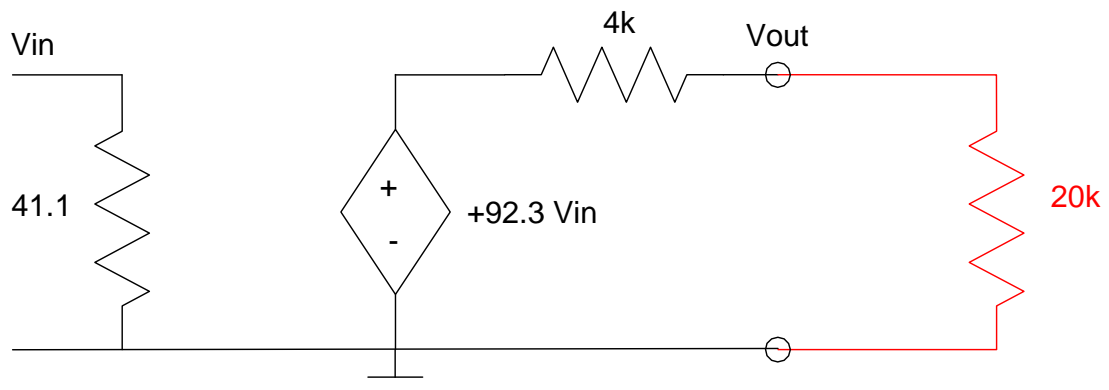

3) Common Collector Amplifier:

3a) Draw the small circuit equivalent for this circuit configured as a common collector amplifier driving a 20k load

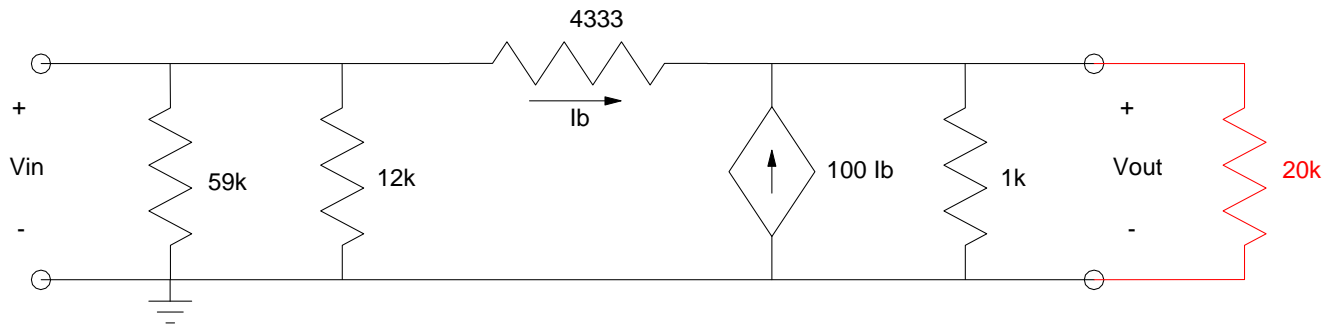

3b) Determine the 2-port model for this amplifier.

$$R_{in} = 59k \parallel 12k \parallel 4333 = 3020\Omega$$

$$A_{in} = \left(\frac{12k \parallel 59k}{12k \parallel 59k + 4333} \right) = 0.6971$$

$$R_{out} = 1k \parallel 4333 \parallel \frac{4333}{100} = 41.1\Omega$$

$$A_{out} : \left(\frac{X-1}{4333} \right) + 100 \left(\frac{X-1}{4333} \right) + \left(\frac{X}{1000} \right) = 0$$

$$X = A_o = \left(\frac{\frac{101}{4333}}{\frac{101}{4333} + \frac{1}{1000}} \right) = 0.9589$$

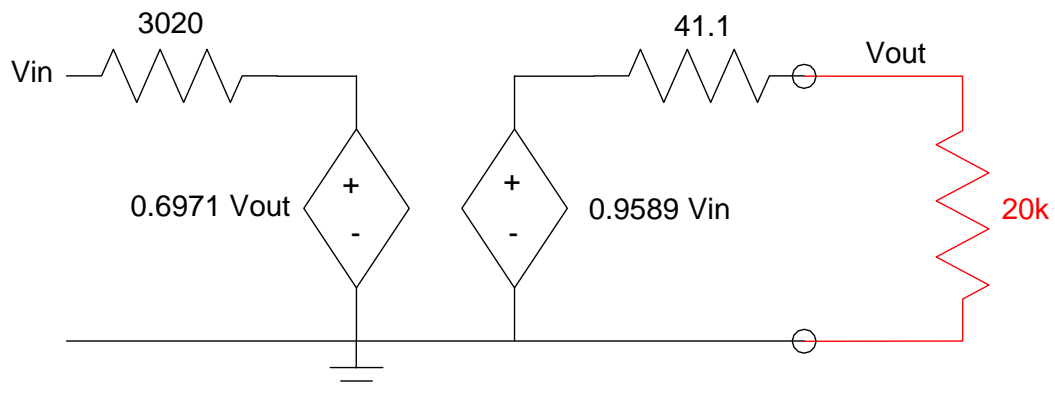

4) Determine the 2-port model for a 4-stage amplifier:

CB : CE : CE : CC

First, find the 2-port model for a CE : CC combination

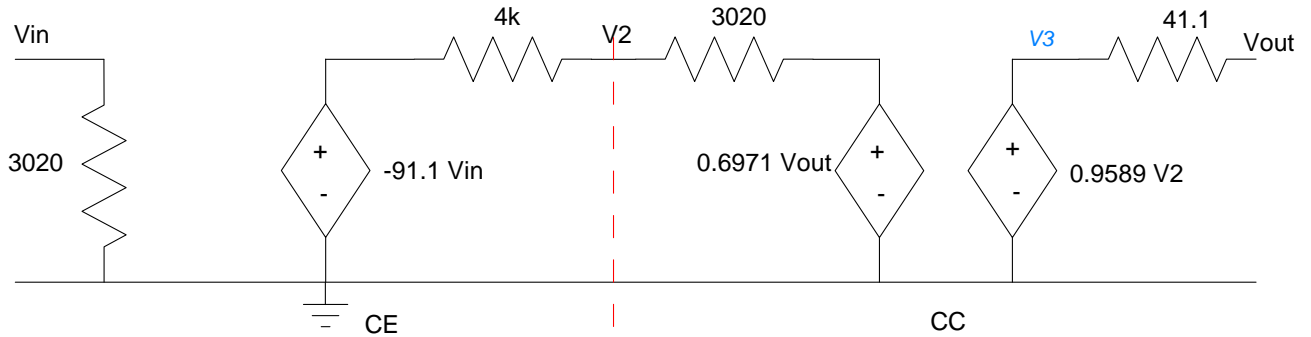

$$R_{in} = 3020$$

$$A_{in} = 0$$

Rout: Short Vin. Apply 1V to Vout. Measure the current

$$V_2 = \left(\frac{4k}{4k+3020} \right) 0.6971 = 0.3972V$$

$$V_3 = 0.9589V_2 = 0.3809V$$

$$I = \left(\frac{1-0.3809}{41.1} \right)$$

$$R_{out} = \frac{1}{I} = \left(\frac{41.1}{1-0.3809} \right) = 66.4\Omega$$

Aout: Apply 1V to Vin, measure Vout

$$V_2 = \left(\frac{3020}{3020+4k} \right) (-91.1) + \left(\frac{4k}{4k+3020} \right) (0.6981) 0.9589V_2$$

$$V_2 = \left(\frac{\left(\frac{3020}{3020+4k} \right)}{1 - \left(\frac{4k}{4k+3020} \right) (0.6981) 0.9589} \right) \cdot (-91.1) = -63.3$$

$$V_o = 0.9589V_2 = -60.7$$

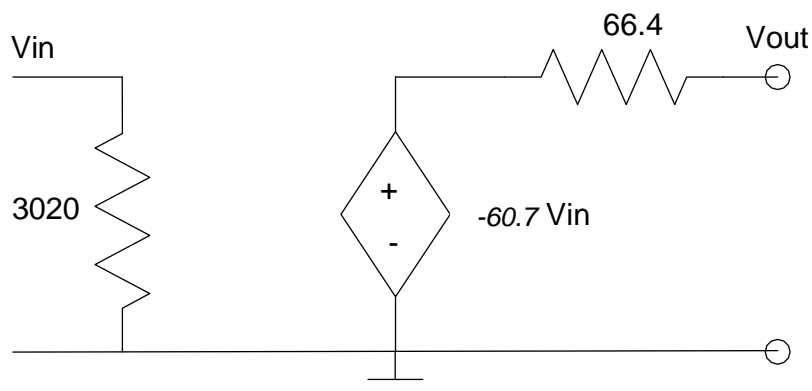

Now add a CB : CE in front

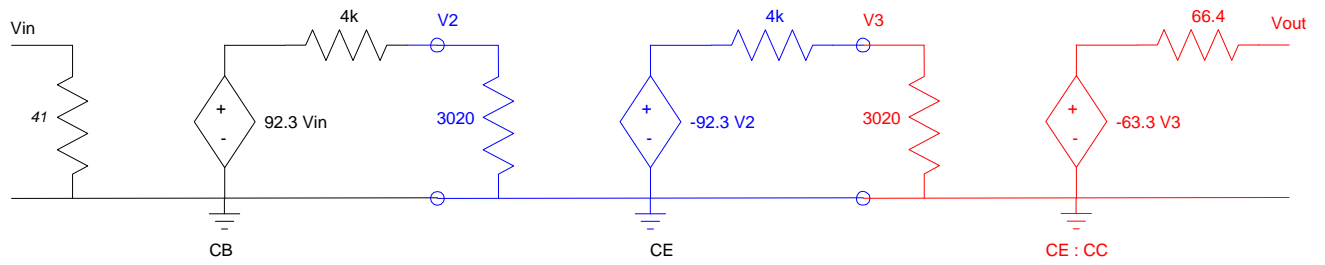

$$R_{in} = 3020$$

$$A_{in} = 0$$

$$R_{out} = 66.4$$

$$A_{out} = 92.3 \cdot \left(\frac{3020}{3020+4k} \right) \cdot (92.3) \cdot \left(\frac{3020}{3020+4k} \right) \cdot (-66.3) = -104,533$$

