

# ECE 461/661 - Test #1: Name \_\_\_\_\_

Fall 2020

1) Determine the function  $Y = f(A, B, C, D)$  for the following ladder logic circuit. (you don't need to simplify)

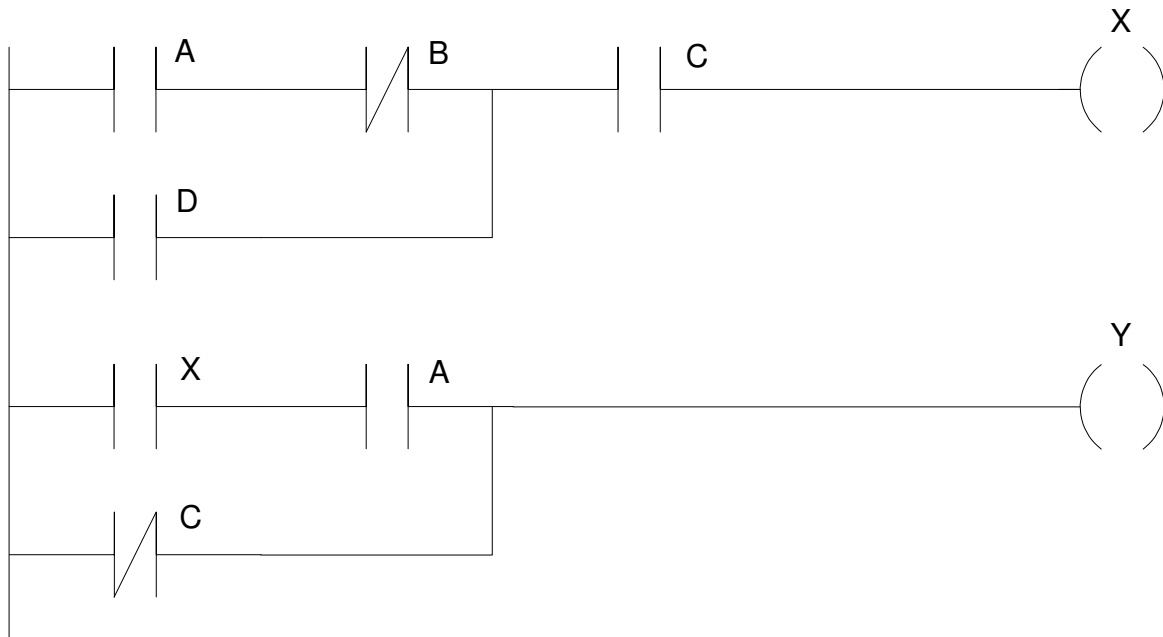

2) Give the transfer function for a system with the following response to a unit step input:

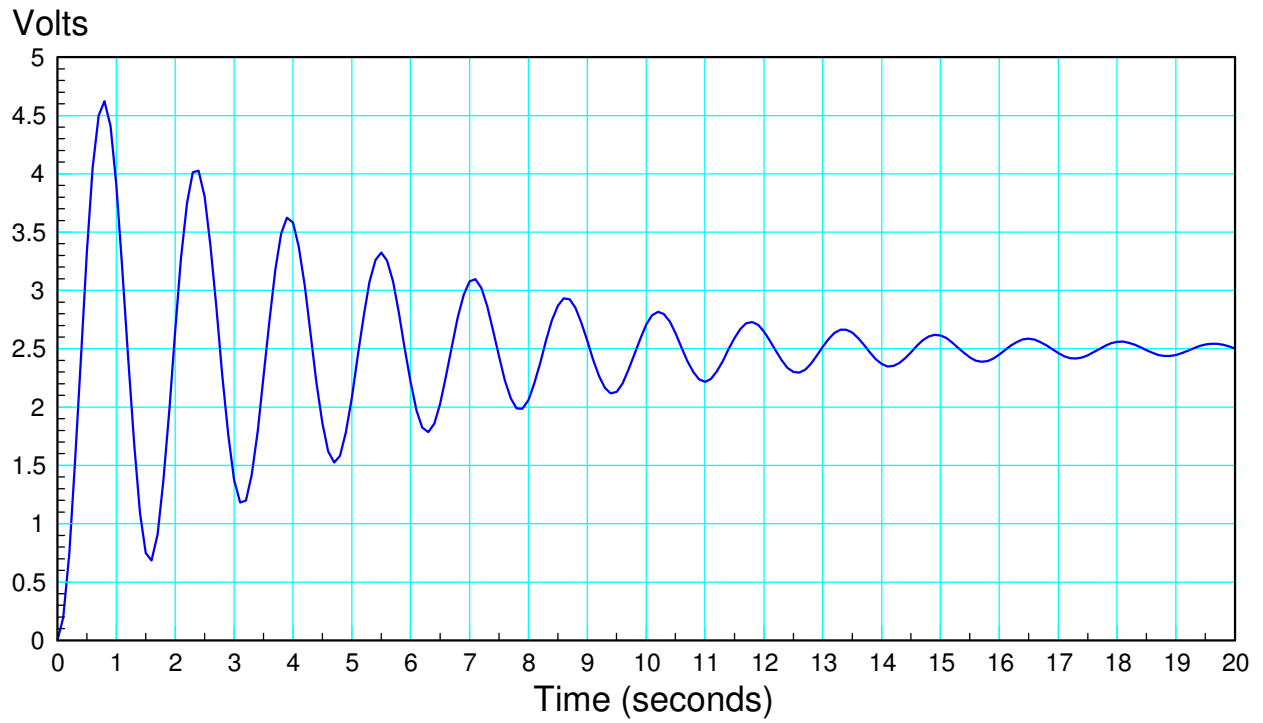

3) Find the transfer function from X to Y

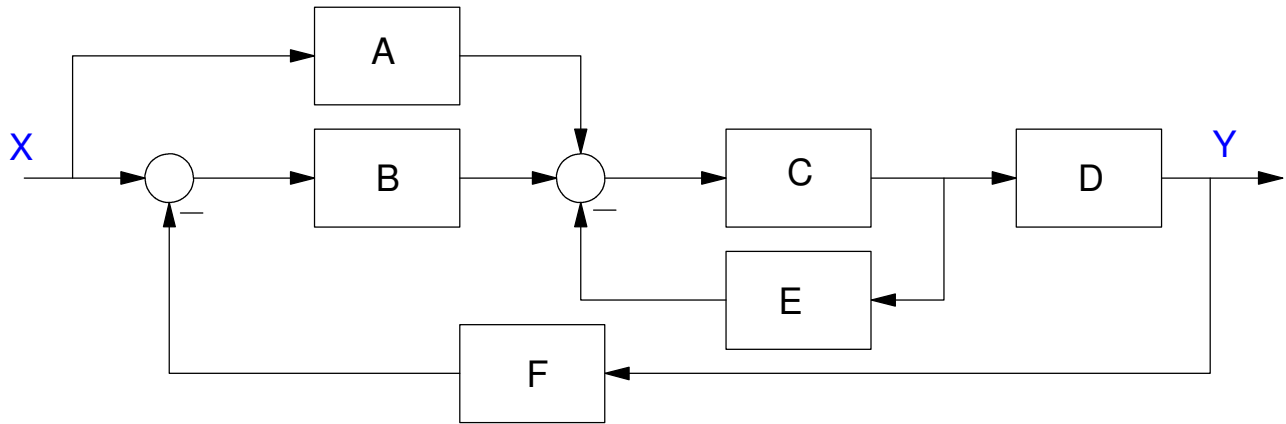

4) For the following RLC circuit:

- Write the dynamics of this system as four coupled differential equations in terms of  $\{V_{in}, V_1, V_2, I_3, I_4\}$
- Express these dynamics in state-space form

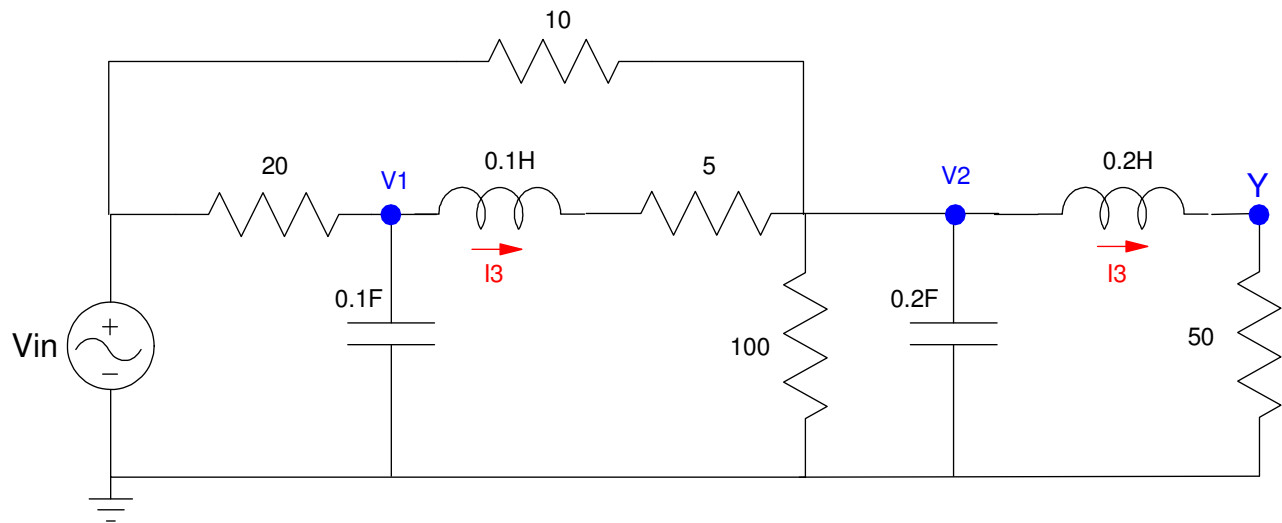

5) For the following mass-spring system

- Draw the circuit equivalent for the following mass-spring system
- Write the equations of motion (i.e. write the voltage node equations)

