

# ECE 463/663 - Homework #2

State-Space, Eigenvalues, Eigenvectors. Due Monday, Jan 25th

Please make the subject "ECE 463/663 HW#2" if submitting homework electronically to Jacob\_Glower@yahoo.com (or on blackboard)

1) For the following RLC circuit

- Specify the dynamics for the system (write  $N$  coupled differential equations)
- Express these dynamics in state-space form
- Determine the transfer function from  $V_{in}$  to  $Y$

2) For the transfer function from  $V_{in}$  to  $Y$

- Determine a 1st or 2nd-order approximation for this transfer function
- Plot the step response of the actual 5th-order system and its approximation

3) For this circuit...

- What initial condition will the energy in the system decay as slowly as possible?
- What initial condition will the energy in the system decay as fast as possible?

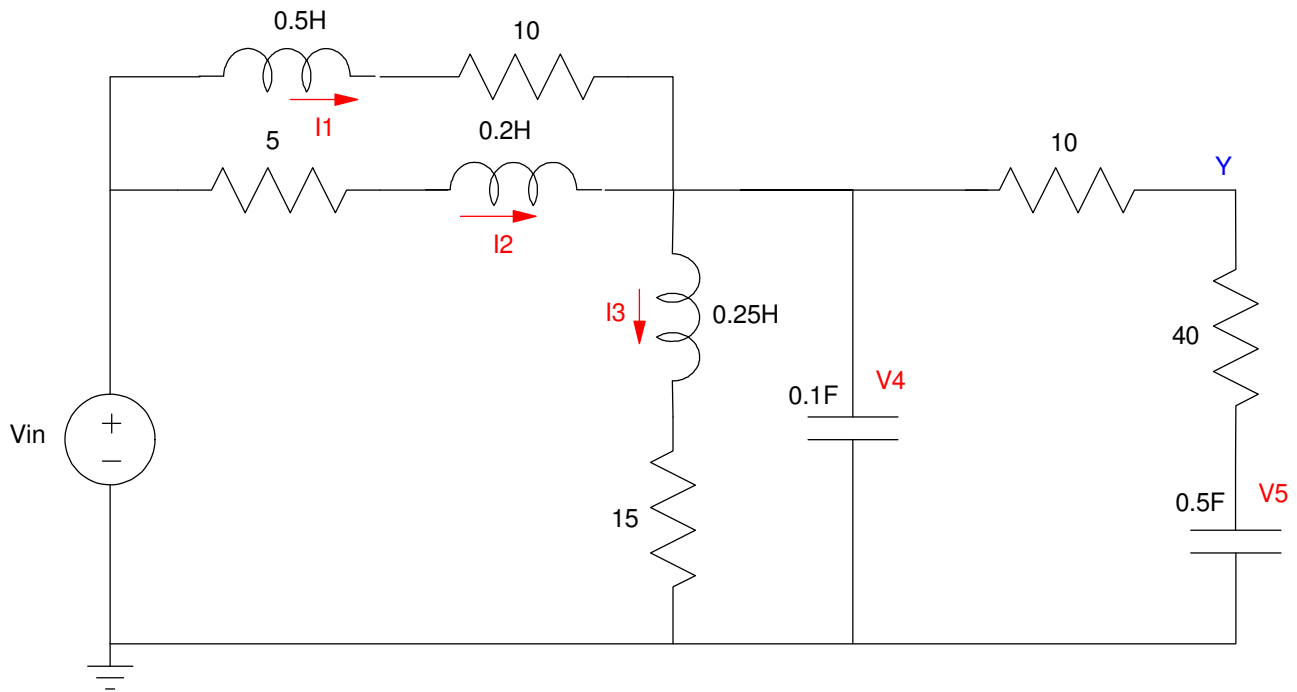

Problem 1 - 3

Problem 4-7: 10-Stage RC Filter.

*note: You can turn in the Matlab code along with screen shots of the plots if you like.*

4) For the following 10-stage RC circuit

- Specify the dynamics for the system (write N coupled differential equations)
  - note: Nodes 1..9 have the same form. Just write the node equation for node 1 and node 10.
- Express these dynamics in state-space form
- Determine the transfer function from  $V_{in}$  to  $V_{10}$

5) For the transfer function for problem #4

- Determine a 2nd-order approximation for this transfer function
- Plot the step response of the actual 10th-order system and its 2nd-order approximation

6) For the circuit for problem #4

- What initial condition will decay as slowly as possible?
- What initial condition will decay as fast as possible?

7) Modify the program *heat.m* to match the dynamics you calculated for this problem.

- Give the program listing
- Give the response for  $V_{in} = 0$  and the initial conditions being
  - The slowest eigenvector
  - The fastest eigenvector
  - A random set of voltages

