

ECE 463/663 - Homework #10

LQG Control with Servo Compensators. Due Monday, April 11th, 2022

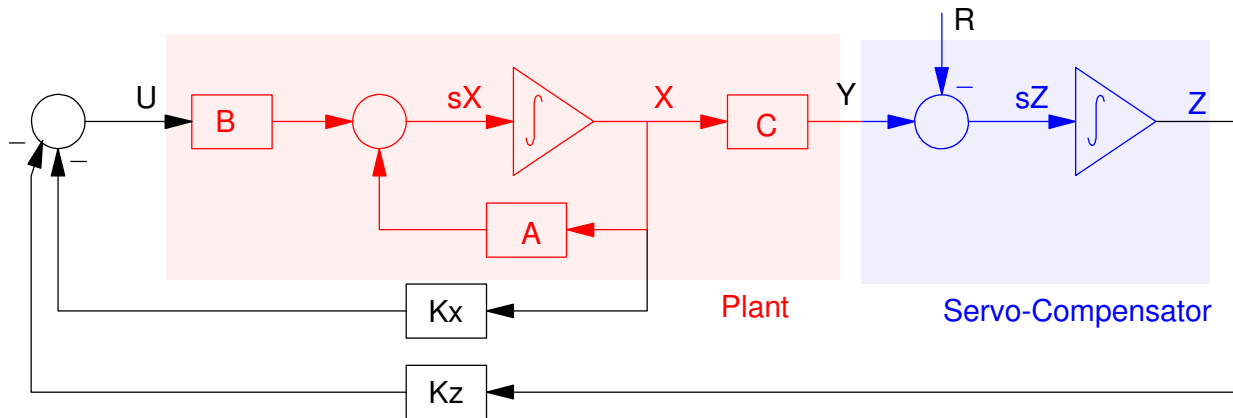

Cart and Pendulum (HW #4): For the cart and pendulum system of homework #4

$$s \begin{bmatrix} x \\ \theta \\ \dot{x} \\ \dot{\theta} \end{bmatrix} = \begin{bmatrix} 0 & 0 & 1 & 0 \\ 0 & 0 & 0 & 1 \\ 0 & -14.7 & 0 & 0 \\ 0 & 24.5 & 0 & 0 \end{bmatrix} \begin{bmatrix} x \\ \theta \\ \dot{x} \\ \dot{\theta} \end{bmatrix} + \begin{bmatrix} 0 \\ 0 \\ 0.5 \\ -0.5 \end{bmatrix} F$$

Use LQG methods to design a full-state feedback control law of the form

$$F = U = -K_z Z - K_x X$$

$$\dot{Z} = (x - R)$$

for the cart and pendulum system from homework #4 using LQG control so that

- You track constant setpoints,
- You reject constant disturbances,
- The 2% settling time is 10 seconds, and
- There is less than 10% overshoot for a step input.

- 1) Give the control law (K_x and K_z) and explain how you chose Q and R
- 2) Plot the step response of the linear system
- 3) Check your design with the nonlinear simulation of the cart and pendulum system.

Ball and Beam (HW #4): For the ball and beam system of homework #4

$$s \begin{bmatrix} r \\ \theta \\ \dot{r} \\ \dot{\theta} \end{bmatrix} = \begin{bmatrix} 0 & 0 & 1 & 0 \\ 0 & 0 & 0 & 1 \\ 0 & -7 & 0 & 0 \\ -4.2 & 0 & 0 & 0 \end{bmatrix} \begin{bmatrix} r \\ \theta \\ \dot{r} \\ \dot{\theta} \end{bmatrix} + \begin{bmatrix} 0 \\ 0 \\ 0 \\ 0.143 \end{bmatrix} T$$

Use LQG methods to design a full-state feedback control law of the form

$$T = U = -K_z Z - K_x X$$

$$\dot{Z} = (x - R)$$

for the ball and beam system from homework #6 using LQG control so that

- You track constant setpoints,
- You reject constant disturbances,
- The 2% settling time is 6 seconds, and
- There is less than 5% overshoot for a step input.

4) Give the control law (K_x and K_z) and explain how you chose Q and R

5) Plot the step response of the linear system

6) Check your design with the nonlinear simulation of the cart and pendulum system.